



*Catalogue*

# Pièces d'usures au CARBURE

 **AGRI-POWER**

CARBIDE WEARING PARTS  
REPUESTOS DE CARBURO DE TUNGSTENO  
PEÇAS DE DESGASTE DE CARBONETO  
CZĘŚCI ZUŻYWAJĄCE SIĘ Z WĘGLIKÓW SPIEKANYCH  
HARTMETALL VERSCHLEOSSTEILE

# AGRI-POWER

## pièces d'usure au carbure

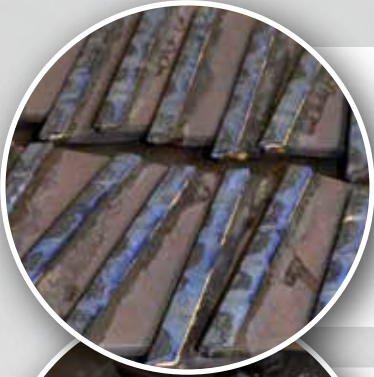

- **DURETÉ DU SUPPORT ATTESTÉE (> 45HRC)**

Aciers sélectionnés selon cahier des charges "Agri-Power" dans des forges partenaires.

*High hardness nwked wear parts (>45 HRC for forged parts)*

*Dureza del soporte probada (>45 HRC para piezas forjadas)*

*Dureza certificada da substração (> 45hrc) aços seleccionados de acordo com as especificações "agri-power" em forjas parceiras*

*Certyfikowana twardość podłoża (> 45hrc) stale wybrane zgodnie ze specyfikacjami "agri-power" w kuźniach partnerskich.*

*Hohe Härte der Ausgangsmaterialien (>45 HRC bei Schmiedeteilen)*

- **PROCESS DE BRASAGE PAR INDUCTION MAÎTRISÉ AVEC UNE BRASURE HAUTE TENEUR D'ARGENT**

*Specific brazing process*

*Proceso de soldadura controlado*

*Processo de brasagem por indução controlada com uma liga de brasagem com elevado teor de prata*

*Kontrolowany proces lutowania indukcyjnego z użyciem stopu lutowniczego o wysokiej zawartości ar-gentu*

*Spezielles Lötverfahren*

- **RECHARGEMENT DÉPOSÉ AVEC PRÉCISION ET RESPECT DU SUPPORT**

*A respectful hardfacing placed with precision on the support*

*Recargo realizado con precisión y respeto del soporte*

*Recarga depositada com precisão e respeito do suporte*

*Przeładowywanie z precyzją i poszanowaniem podłoża*

*Geleistete Verschleiß mit Genauigkeit*

- **FINITION GRENAILLÉE POUR UNE MEILLEURE PRÉSENTATION DANS VOS MAGASINS**

*Sandblasted finish*

*Acabado grenallado*

*Acabamento jateado para uma melhor apresentação nas suas lojas*

*Śrutowane wykończenie dla lepszej prezentacji w waszych sklepach*

*Sandgestrahltes Endprodukt*







# BOULONNERIE

## LABOUR

 Tillage  
 Trabajo del suelo  
 Lavoura  
 Orka  
 Bodenbearbeitung

6

## PRÉPARATION DU SOL

 Soil preparation  
 Preparación del suelo  
 Preparação do solo  
 Przygotowanie gleby  
 Bodenvorbereitung





20

## DÉCHAUMAGE

 Stubble Ploughing  
 Arada de rastrojo  
 Lavoura de restolho  
 Orka ścierniskowa  
 Stoppelbearbeitung





38

## SOUS-SOLAGE

 Subsoiling  
 Subsuelo  
 Subsolo  
 Uprawa głęboszowa  
 Unterbodenlockerung





52

## VIGNE

 "Vineyard" wearing parts  
 Repuestos de carbura para "la vina"  
 Peças de desgaste « Vinha »  
 Części zużywające się « Winorośl »  
 Verschleissteile für "Rebe"





62

## MISES À SOUDER

 Flat weld-on strips  
 Piezas para soldar planas  
 Peças para soldar  
 Elementy do spawania  
 Flach Anweißteilen

68

## BOULONNERIE

 Nuts and bolts  
 Tornillería  
 Parafusos e porcas  
 Śruby  
 Schrauben und Muttern

78

# AMÉLIOREZ LES PROPRIÉTÉS TECHNIQUES DES CHARRUES

IMPROVE THE PLOUGH TECHNICAL QUALITIES | MEJORAR LAS CUALIDADES TÉCNICAS DEL ARADO |  
MELHORAR AS CARACTERÍSTICAS TÉCNICAS DAS CHARRUAS | POPRAWA WŁAŚCIWOŚCI TECHNICZNYCH PŁUGÓW |  
VERBESSERUNG DER TECHNISCHEN EIGENSCHAFTEN DES PFLUGES

- **Pièces forgées très haute dureté, respectant strictement les éléments de la charrue**

*Heavy duty forged parts*

*Partes forjadas alta dureza*

*Peças forjadas extremamente duras, rigorosamente em conformidade com os componentes do arado*

*Niezwykle twarde części kute, ściśle dopasowane do elementów pługa*

*Schmiedestücker hoher Härte*

- **Deux gammes de pointes : standards ou rechargées pour toutes les utilisations**

*Standard and hardfaced point ranges for all uses*

*Partes recargadas y estandares para todos los usos*

*Duas gamas de pontas: standard ou recarregadas para todas as aplicações*

*Dwie gamy dłut : standardowe lub ponownie ładowane do wszystkich zastosowań*

*Werkstück und Standardteile für jede Verwendungsart*

- **Socs de rasettes très résistants avec rechargement de série**

*Tougher skim points with hardfacing*

*Rasetas muy resistentes con recargo*

*Bases de raspadeiras resistentes com recarga standard*

*Bardzo odporne lemieszki przedpłużka ze standardowym przeładowaniem*

*Voschälerschar mit Verschleiß*

- **Face d'appui des contreseps protégée par des plaquettes carbure pour une meilleure durée de vie**

*Protected landsides with carbide plates*

*Taloneras protegidas con placas de carburo*

*Face de apoio protegida por pastilhas de carboneto para uma vida útil mais longa*

*Powierzchnia płozy chroniona wkładkami z węglików spiekanych dla dłuższej żywotności*

*Geschützte Anlagen mit Hartmetallplatten*



# LABOUR

 TILLAGE |  TRABAJO DEL SUELO |  LAVOURA |  
 ORKA |  BODENBEARBEITUNG



 **AGRI-POWER**



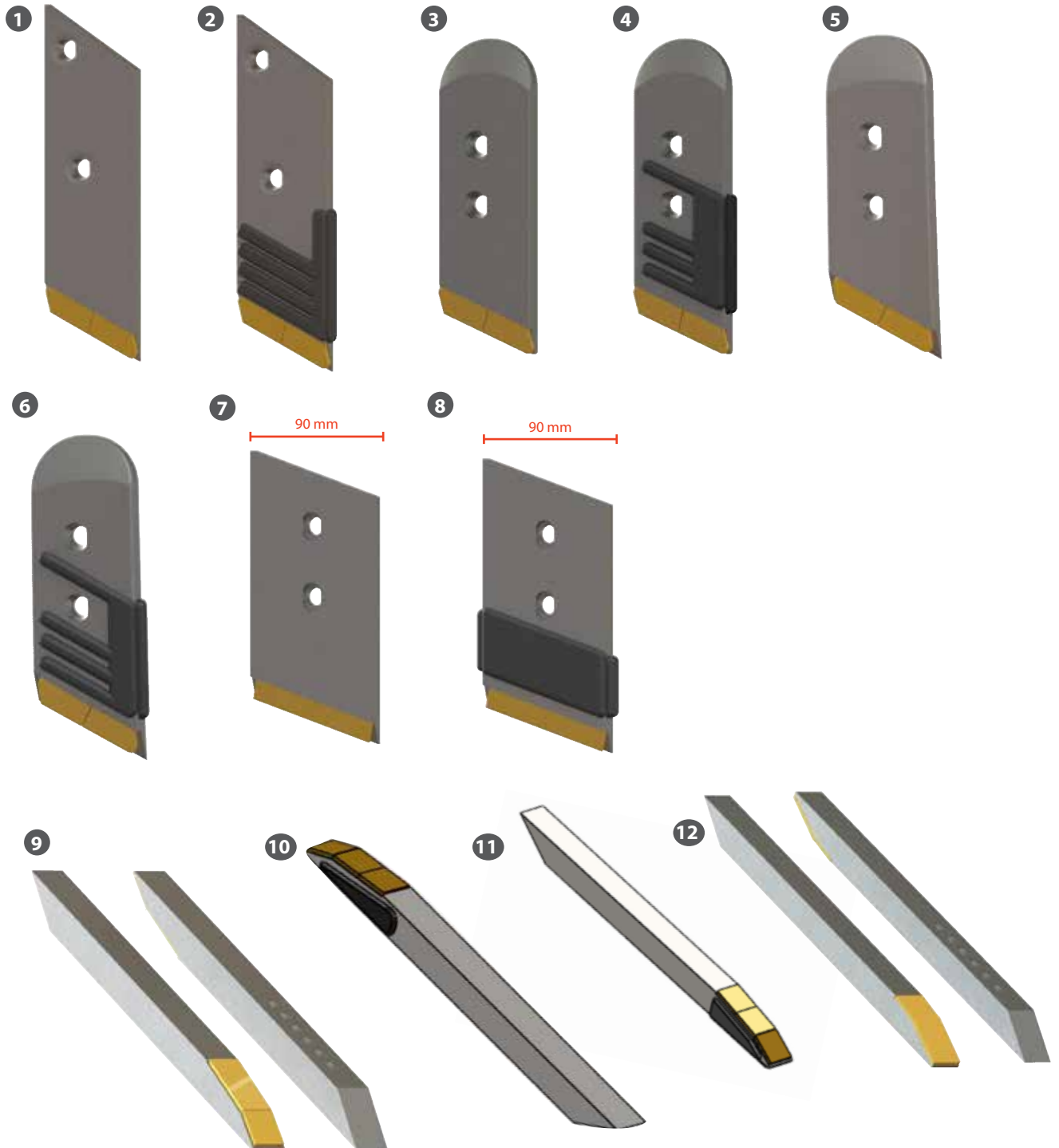

-  Plough points
-  Puntas de arado
-  Pontas de charrua
-  Dłuto pluga
-  Pflugspitzen

# POINTES DE CHARRUES





# POINTES DE CHARRUES

	Montage sur marques	Rechargement				OEM			OEM	
	Type Para tipo Tipo Typ Passend zu	Hardfacing Recarga Recarga Przeładowywanie Hartmetall AusschweiBen								
1	<b>BRIX</b>		5940324 TC2M 12 x 38	2,35 kg	90 mm	415257	<b>400687</b>		-	
2		✓	5940324 TC2M 12 x 38	2,45 kg	90 mm	415257	<b>400688</b>		-	
3	<b>DOWDESWELL</b>		5940324 TC2M 12 x 38	2,50 kg	45 mm	901954	<b>400851</b>	<b>400850</b>	901953	
4		✓	5940324 TC2M 12 x 38	2,55 kg	45 mm	901954	<b>400853</b>	<b>400852</b>	901953	
5	<b>DURO</b>		5940324 TC2M 12 x 38	2,34 kg	50 mm	6431	<b>217955</b>	<b>217954</b>	6432	
6		✓	5940324 TC2M 12 x 38	2,39 kg	50 mm	6431	<b>219161</b>	<b>219160</b>	6432	
7			5940324 TC2M 12 x 38	2,50 kg	50 mm	6431	<b>208074</b>	<b>208073</b>	6432	
8		✓	5940324 TC2M 12 x 38	2,55 kg	50 mm	6431	<b>208076</b>	<b>208075</b>	6432	
5	<b>GOIZIN</b>		5940324 TC2M 12 x 38	2,34 kg	50 mm	010154	<b>217955</b>	<b>217954</b>	010104	
6		✓	5940324 TC2M 12 x 38	2,39 kg	50 mm	010154	<b>219161</b>	<b>219160</b>	010104	
7			5940324 TC2M 12 x 38	2,50 kg	50 mm	010154	<b>208074</b>	<b>208073</b>	010104	
8		✓	5940324 TC2M 12 x 38	2,55 kg	50 mm	010154	<b>208076</b>	<b>208075</b>	010104	
5	<b>GRÉGOIRE - BESSON</b>		5940324 TC2M 12 x 38	2,34 kg	50 mm	173464-173332 173342	<b>217955</b>	<b>217954</b>	173463 - 173331 173341	
6		✓	5940324 TC2M 12 x 38	2,39 kg	50 mm	173464-173332 173342	<b>219161</b>	<b>219160</b>	173463 - 173331 173341	
7			5940324 TC2M 12 x 38	2,50 kg	50 mm	173464 - 173332 173342	<b>208074</b>	<b>208073</b>	173463 - 173331 173341	
8		✓	5940324 TC2M 12 x 38	2,55 kg	50 mm	173464 - 173332 173342	<b>208076</b>	<b>208075</b>	173463 - 173331 173341	
9			-	-	4,30 kg	-	172330	<b>209093</b>		-
10		✓	-	-	4,35 kg	-	172330	<b>209902</b>		-
11		✓	-	-	4,50 kg	-	172330	<b>400821</b>	<b>400820</b>	172330
12			-	-	3,10 kg	-	171207	<b>400671</b>		-



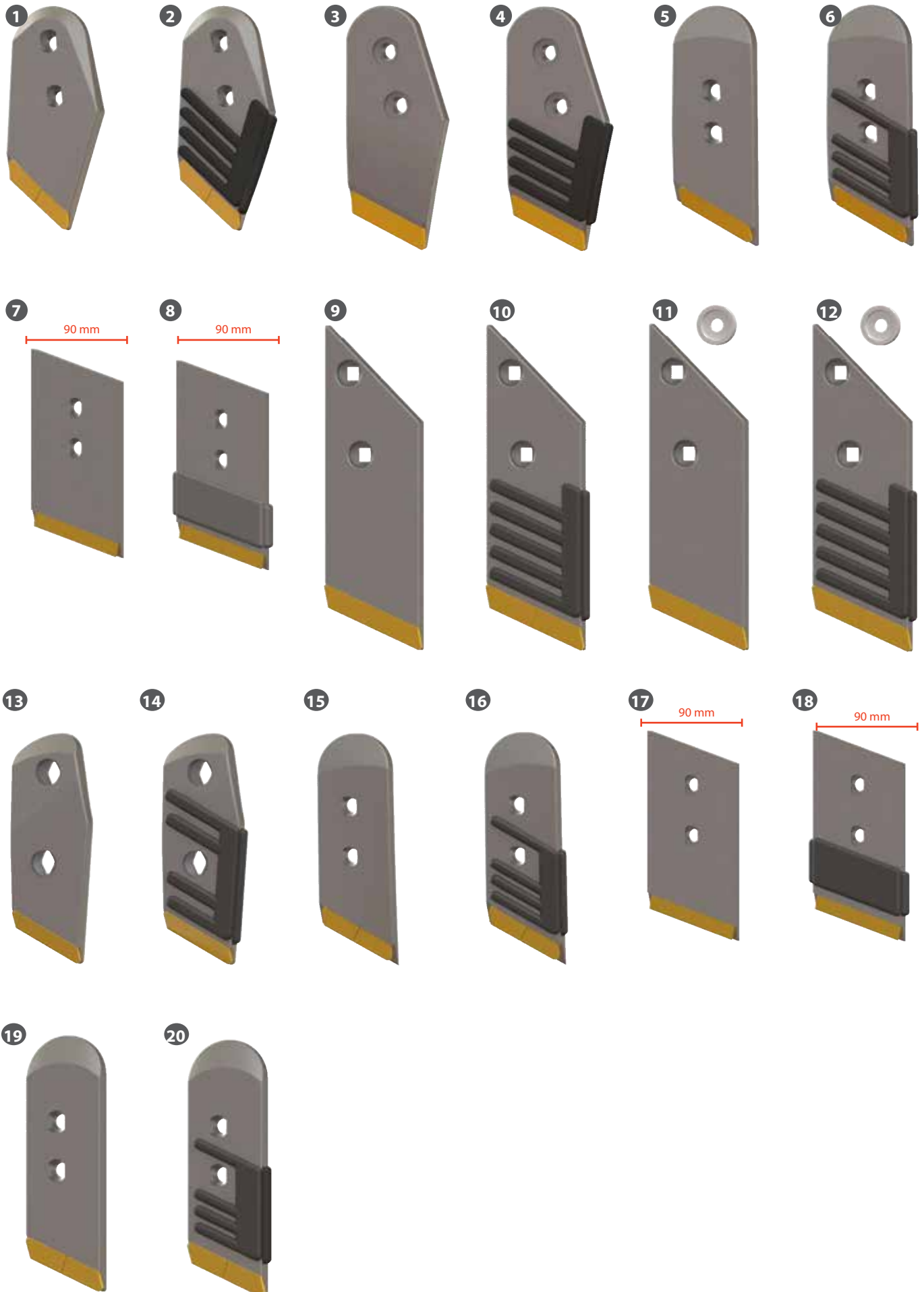

-  Plough points
-  Puntas de arado
-  Pontas de charrua
-  Dłuto pluga
-  Pflugspitzen

# POINTES DE CHARRUES





## POINTES DE CHARRUES

	Montage sur marques	Rechargement				OEM			OEM
	Type Para tipo Tipo Typ Passend zu	Hardfacing Recarga Recarga Przeładowywanie Hartmetall Auschweißen							
1	KUHN		5940324 TC2M 12 x 38	2,25 kg	52 mm	622129 / 622165	217597	217596	622128 / 622164
2		✓	5940324 TC2M 12 x 38	2,30 kg	52 mm	622129 / 622165	219159	219158	622128 / 622164
3		<b>HEAVY DUTY</b>	5940324 TC2M 12 x 38	2,70 kg	52 mm	622129 / 622165	400833	400832	622128 / 622164
4		<b>HEAVY DUTY</b> ✓	5940324 TC2M 12 x 38	2,75 kg	52 mm	622129 / 622165	400883	400882	622128 / 622164
5	KVERNELAND		5940324 TC2M 12 x 38	2,56 kg	40 mm	063090	217959	217958	053090
6		✓	5940324 TC2M 12 x 38	2,61 kg	40 mm	063090	219163	219162	053090
7			5940324 TC2M 12 x 38	2,50 kg	40 mm	063090	209220	209219	053090
8		✓	5940324 TC2M 12 x 38	2,55 kg	40 mm	063090	209222	209221	053090
9	LEMKEN		5915220 TFCC 12 x 40	3,70 kg	85 mm	3364055	206213	206212	3364054
10		✓	5915220 TFCC 12 x 40	3,75 kg	85 mm	3364055	206215	206214	3364054
11	LEMKEN (JUWEL)		5915220 TFCC 12x40	3,76 kg	85 mm	3364057	412308	412307	3364057
12		✓	5915220 TFCC 12x40	3,81 kg	85 mm	3364057	412310	412309	3364056
		Rondelle incluse		0,06 kg			400929		
9	MASCHIO		5915220 TFCC 12 x 40	3,70 kg	85 mm	(SIRO)	206213	206212	(SIRO)
10		✓	5915220 TFCC 12 x 40	3,75 kg	85 mm	(SIRO)	206215	206214	(SIRO)
13	NAUD		5925215 TF2E 14 x 40	2,57 kg	90 mm	031235	217957	217956	031235
14		✓	5925215 TF2E 14 x 40	2,62 kg	90 mm	031235	206177	206176	031235
9	OPALL AGRI		5915220 TFCC 12 x 40	3,70 kg	85 mm	40411 - 04112	206213	206212	40411 - 04220
10		✓	5915220 TFCC 12 x 40	3,75 kg	85 mm	40411 - 04112	206215	206214	40411 - 04220
15	PÖTTINGER		5940324 TC2M 12 x 38	2,34 kg	50 mm	930211250	217955	217954	930201250
16		✓	5940324 TC2M 12 x 38	2,39 kg	50 mm	930211250	219161	219160	930201250
17			5940324 TC2M 12 x 38	2,50 kg	50 mm	930211250	208074	208073	930201250
18		✓	5940324 TC2M 12 x 38	2,55 kg	50 mm	930211250	208076	208075	930201250
5			5940324 TC2M 12 x 38	2,56 kg	40 mm	6763090	217959	217958	6753090
6		✓	5940324 TC2M 12 x 38	2,61 kg	40 mm	6763090	219163	219162	6753090
7			5940324 TC2M 12 x 38	2,50 kg	40 mm	6763090	209220	209219	6753090
8		✓	5940324 TC2M 12 x 38	2,55 kg	40 mm	6763090	209222	209221	6753090
19	RABE		5940324 TC2M 12 x 38	2,50 kg	45 mm	MP 332	400851	400850	MP 332
20		✓	5940324 TC2M 12 x 38	2,55 kg	45 mm	MP 332	400853	400852	MP 332
19	RANSOMES		5940324 TC2M 12 x 38	2,50 kg	45 mm	-	400851	400850	-
20		✓	5940324 TC2M 12 x 38	2,55 kg	45 mm	-	400853	400852	-



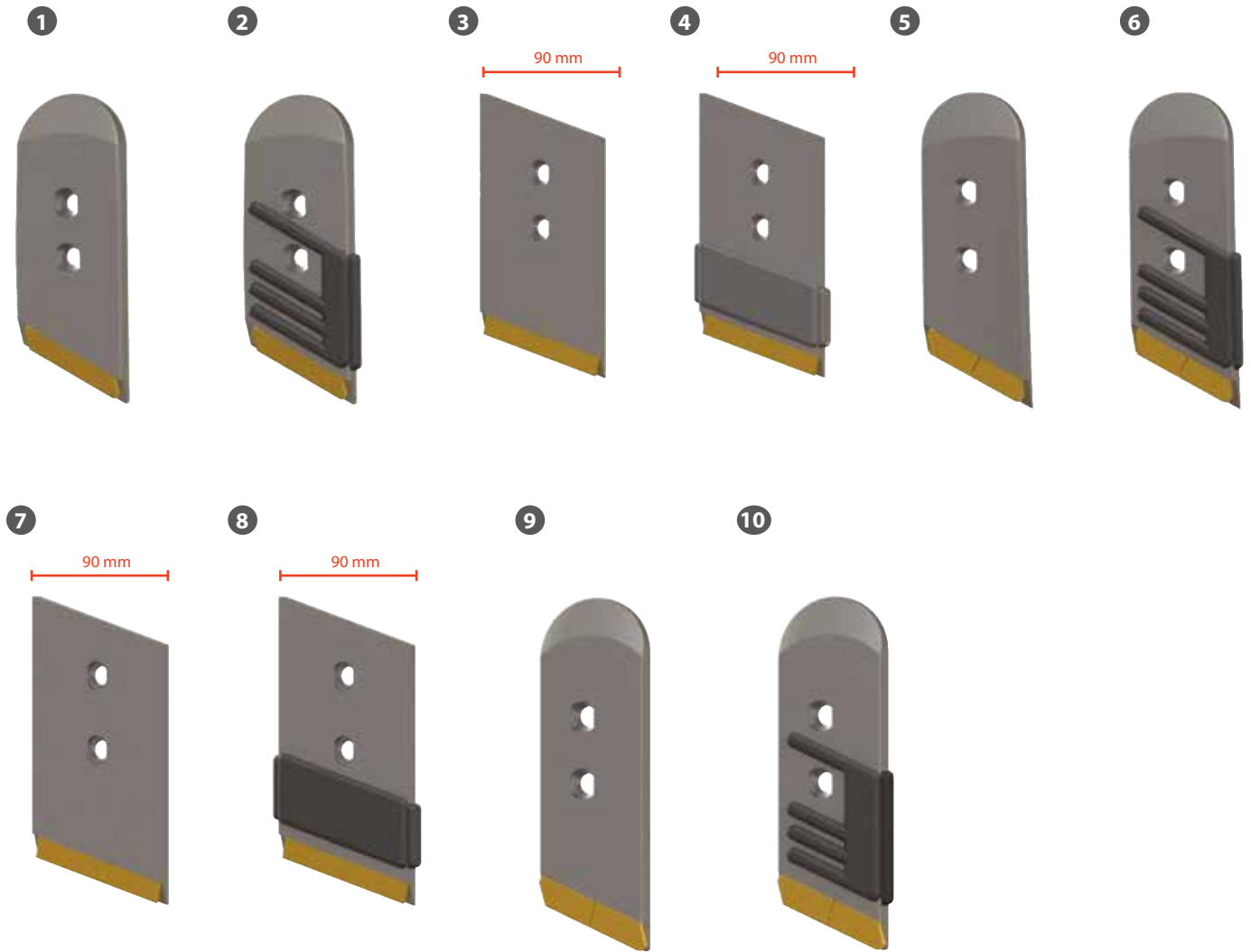

-  Plough points
-  Puntas de arado
-  Pontas de charrua
-  Dłuto pluga
-  Pflugspitzen

# POINTES DE CHARRUES





# POINTES DE CHARRUES

	Montage sur marques	Rechargement				OEM		OEM	
	Type Para tipo Tipo Typ Passend zu	Hardfacing Recarga Recarga Przeladowywanie Hartmetall AuschweiBen							
1	<b>SOUCHU - PINET</b>		5940324 TC2M 12 x 38	2,56 kg	40 mm	1189	<b>217959</b>	1188	<b>217958</b>
2		✓	5940324 TC2M 12 x 38	2,61 kg	40 mm	1189	<b>217163</b>	1188	<b>219162</b>
3			5940324 TC2M 12 x 38	2,50 kg	40 mm	1189	<b>209220</b>	1188	<b>209219</b>
4		✓	5940324 TC2M 12 x 38	2,55 kg	40 mm	1189	<b>209222</b>	1188	<b>209221</b>
5	<b>THIEME</b>		5940324 TC2M 12 x 38	2,34 kg	50 mm	260192	<b>217955</b>	260191	<b>217954</b>
6		✓	5940324 TC2M 12 x 38	2,39 kg	50 mm	260192	<b>219161</b>	260191	<b>219160</b>
7			5940324 TC2M 12 x 38	2,50 kg	50 mm	260192	<b>208074</b>	260191	<b>208073</b>
8		✓	5940324 TC2M 12 x 38	2,55 kg	50 mm	260192	<b>208076</b>	260191	<b>208075</b>
9	<b>UNIA</b>		5940324 TC2M 12 x 38	2,50 kg	45 mm	1150/72-201/0	<b>400851</b>	1150/72-201/0	<b>400850</b>
10		✓	5940324 TC2M 12 x 38	2,55 kg	45 mm	1150/72-201/0	<b>400853</b>	1150/72-201/0	<b>400852</b>
5	<b>VÖGEL-NOOT</b>		5940324 TC2M 12 x 38	2,34 kg	50 mm	PK 0801102	<b>217955</b>	PK 0801101	<b>217954</b>
6		✓	5940324 TC2M 12 x 38	2,39 kg	50 mm	PK 0801102	<b>219161</b>	PK 0801101	<b>219160</b>
7			5940324 TC2M 12 x 38	2,50 kg	50 mm	PK 0801102	<b>208074</b>	PK 0801101	<b>208073</b>
8		✓	5940324 TC2M 12 x 38	2,55 kg	50 mm	PK 0801102	<b>208076</b>	PK 0801101	<b>208075</b>

-  Plough shares
-  Rejas de arado
-  Bicos de charrua
-  Lemiesz pluga
-  Pflugschare

# SOCS DE CHARRUES

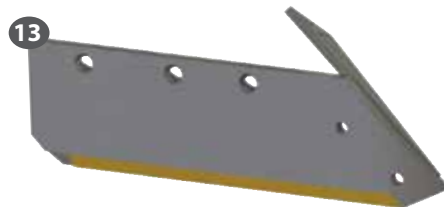
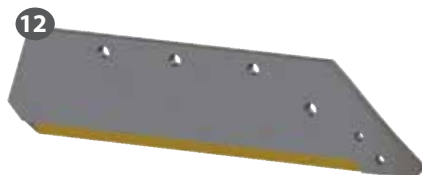
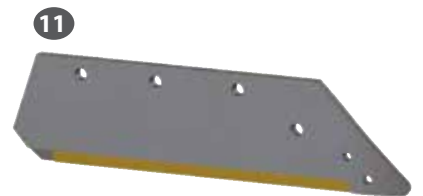
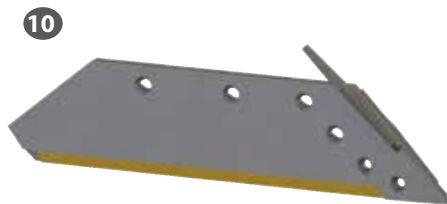
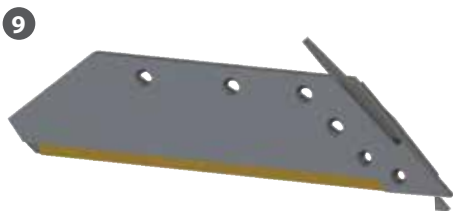
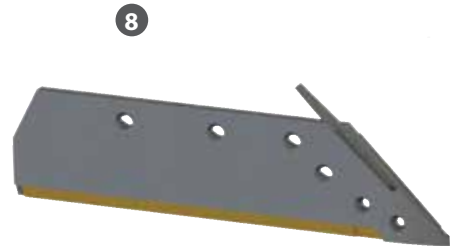
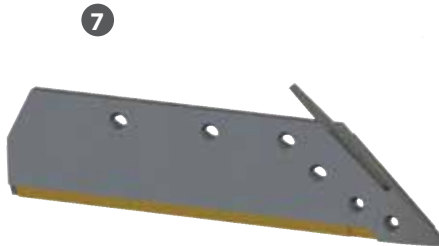
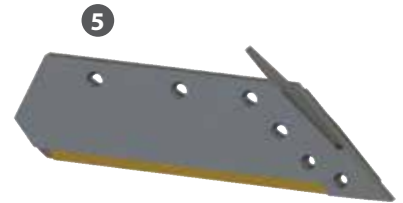
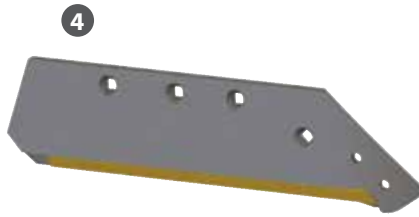
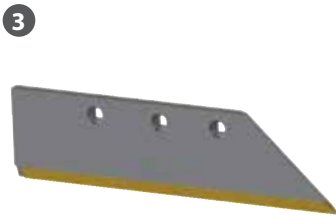
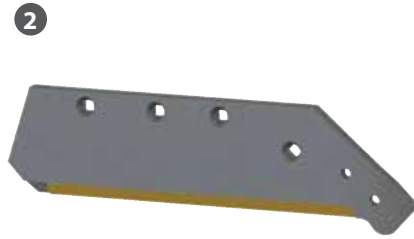
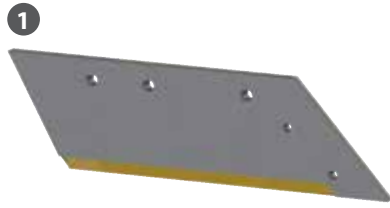



## SOCS DE CHARRUES



	"	Montage sur marques				OEM		OEM	
		Type Para tipo Tipo Typ Passend zu							
1	14"	<b>BRIX</b>	15	5940324 TC2M 12 x 38	8,30 kg	-	-	405127	<b>400689</b>
2	14"	<b>GRÉGOIRE - BESSON</b>	15	5915275 TFCC 14 x 40	7,50 kg	173423/173410	<b>209095</b>	173424/173410	<b>209094</b>
3	16"		15	5915220 TFCC 12 x 40	5,90 kg	172601 - 172613 172615	<b>209097</b>	172602 - 172614 172616	<b>209096</b>
4	16"		15	5915275 TFCC 14 x 40	8,15 kg	173613	<b>209099</b>	173614	<b>209098</b>
5	14"	<b>KUHN</b>	15	5925215 TF2E 14 x 40	7,98 kg	622135	<b>209103</b>	622134	<b>209102</b>
6	14"		15	5925215 TF2E 14 x 40	8,53 kg	580885	<b>400675</b>	580884	<b>400674</b>
7	16"		15	5925215 TF2E 14 x 40	8,80 kg	622235 / 622203	<b>209101</b>	622234 / 622202	<b>209100</b>
8	16"		15	5925215 TF2E 14 x 40	9,35 kg	582865 / 583893	<b>400673</b>	582864 / 583892	<b>400672</b>
9	16"		15	5925215 TF2E 14 x 40	8,90 kg	622137 / 622213	<b>209105</b>	622136 / 622212	<b>209104</b>
10	16"		15	5925215 TF2E 14 x 40	9,45 kg	580887 / 583819	<b>400677</b>	580886 / 583818	<b>400676</b>
11	16"	<b>KVERNELAND</b>	15	5940270 TC1M 14 x 40	7,90 kg	073005	<b>209109</b>	073004	<b>209108</b>
12	18"		15	5940270 TC1M 14 x 40	8,30 kg	073007	<b>400815</b>	073006	<b>400814</b>
13	14"	<b>NAUD</b>	15	5925215 TF2E 14 x 40	8,92 kg	031189	<b>209107</b>	031189	<b>209106</b>



-  Landsides
-  Taloneras
-  Placas de chapa
-  Ploza
-  Anlagen

# CONTRESEPS

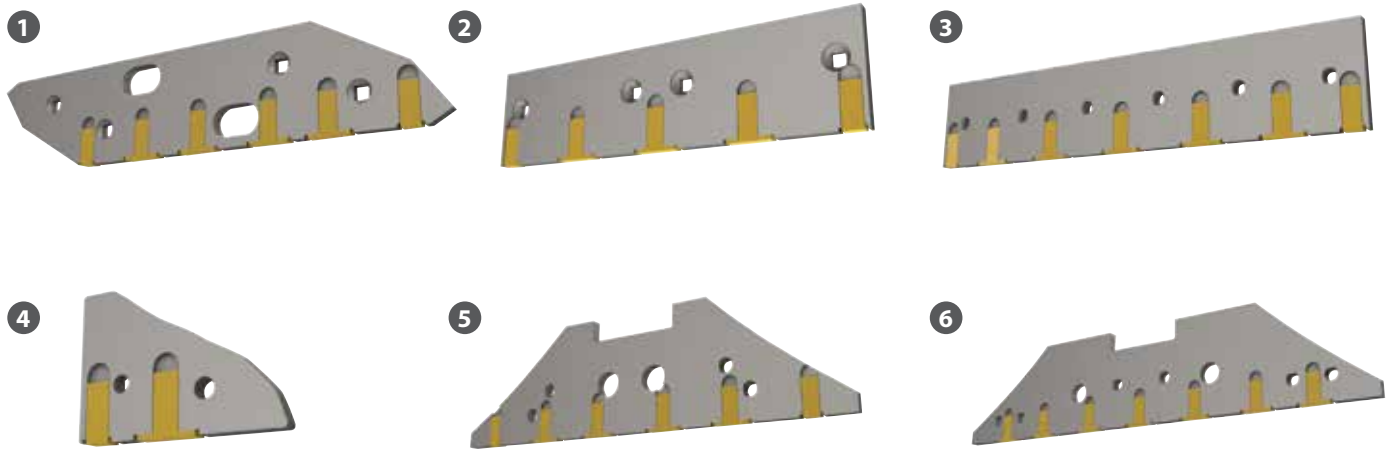





-  Shins
-  Triangulos
-  Láminas
-  Pierś odkładni
-  Streichblechvorderteile







# ETRAVES



## CONTRESEPS

	Montage sur marques				OEM			OEM
	Type Para tipo Tipo Typ Passend zu							
1	<b>GRÉGOIRE - BESSON</b>	15	5915220 TFCC 12 x 40	5,80 kg	173388 G	<b>209316</b>	<b>209315</b>	173388 D
2	<b>LEMKEN</b>	15	5915220 TFCC 12 x 40	5,10 kg	3411504 long A42 D/G	<b>209327</b>		-
3	<b>KUHN</b>	15	5940324 TC2M 12 x 38	6,70 kg	761108 D/G	<b>209318</b>		-
4		15	5940324 TC2M 12 x 38	1,25 kg	761107 G	<b>209320</b>	<b>209319</b>	761106 D
5	<b>KVERNELAND</b>	15	5940270 TC1M 14 x 40	6,65 kg	73608 court D/G	<b>209325</b>		-
6		15	5940270 TC1M 14 x 40	9,95 kg	73609 long D/G	<b>209326</b>		-

## ETRAVES

	Montage sur marques					OEM		OEM	
	Type Para tipo Tipo Typ Passend zu								
1	<b>GRÉGOIRE - BESSON</b>	-	-	2,26 kg	-	172323	<b>400848</b>	172324	<b>400847</b>
2	<b>KVERNELAND</b>	12	5925175 TF2E 12 x 35	2,28 kg	145 mm Ø 12 mm	073251	<b>400652</b>	073250	<b>400651</b>

-  Skim points
-  Rasetas
-  Raspadeiras
-  Przedplużek
-  Vorschälerschare

# RASSETTES



1



2



3



4



5



6



7



8



9



10



11



12



13





# RASETTES

	Montage sur marques	Rechargement					OEM		OEM	
	Type Para tipo Tipo Typ Passend zu	Hardfacing Recarga Przeładowywanie Hartmetall Auschweißen								
1	<b>GOIZIN</b>	✓	12	5915145 TFCC 10 x 40	2,38 kg	65 mm Ø 10 mm	010782	<b>209332</b>	010732	<b>209331</b>
2	<b>GRÉGOIRE - BESSON</b>	✓	12	5915145 TFCC 10 x 40	1,73 kg	55 mm Ø 10 mm	19113 19114	<b>209334</b>	19111 19112	<b>209333</b>
3		✓	12	5915145 TFCC 10 x 40	2,23 kg	83 mm Ø 10 mm	19126	<b>209336</b>	19125	<b>209335</b>
4	<b>KUHN</b>	✓	12	5915220 TFCC 12 x 40	2,30 kg	84 mm Ø 12 mm	631031	<b>209338</b>	631030	<b>209337</b>
6		✓	12	5915220 TFCC 12 x 40	2,32 kg	84 mm	631031	<b>400811</b>	631030	<b>400810</b>
5		✓	12	5915220 TFCC 12 x 40	1,73 kg	64 mm Ø 12 mm	631101	<b>209340</b>	631100	<b>209339</b>
6		✓	12	5915220 TFCC 12 x 40	2,38 kg	64 mm Ø 12 mm	631109	<b>209344</b>	631108	<b>209343</b>
7	<b>KVERNELAND</b>	✓	12	5915145 TFCC 10 x 40	1,73 kg	70 mm Ø 10 mm	066873	<b>209346</b>	056873	<b>209345</b>
8		✓	12	5915145 TFCC 10 x 40	2,60 kg	70 mm Ø 10 mm	066869	<b>209348</b>	066868	<b>209347</b>
9	<b>LEMKEN</b>	✓	12	5915145 TFCC 10 x 40	2,38 kg	87 mm Ø 10 mm	336371	<b>209350</b>	3363710	<b>209349</b>
10		✓	12	5915145 TFCC 10 x 40	1,73 kg	87 mm Ø 10 mm	3363721	<b>209352</b>	3363720	<b>209351</b>
11	<b>NAUD</b>	✓	12	5915145 TFCC 10 x 40	1,73 kg	90 mm Ø 10 mm	031240	<b>209354</b>	031240	<b>209353</b>
12		✓	12	5915145 TFCC 10 x 40	2,38 kg	90 mm Ø 10 mm	031241	<b>209356</b>	031241	<b>209355</b>
13	<b>ÖVERUM</b>	✓	12	5915220 TFCC 12 x 40	2,23 kg	105 mm Ø 12 mm	591802	<b>209358</b>	591801	<b>209357</b>

# UNE GAMME DE DENTS COMPLÈTE POUR TOUTES LES UTILISATIONS

AN EXHAUSTIVE RANGE OF TINES FOR ALL USES | UNA GAMA DE PUNTAS COMPLETA PARA TODOS LOS USOS |  
UMA GAMA COMPLETA DE DENTES PARA TODAS AS APLICAÇÕES | KOMPLETNA GAMA ZĘBÓW DO WSZYSTKICH  
ZASTOSOWAŃ | EINEREIHE KOMPLETTER SPITZEN FÜR ALLE ANWENDUNGEN

- **Sélection des meilleurs supports du marché adaptables et origine**

*Get the best adaptable and genuine parts  
Mejores partes adaptables y origines  
Seleção dos melhores suportes do mercado adaptáveis e originais  
Wybór najlepszych dostosowalnych i oryginalnych nośników na rynku*

- **Plaquettes imbriquées dans le support pour conserver les propriétés tranchantes de la dent**

*Integrated plates in the support to keep the sharp qualities  
Placas integradas en el soporte para preservar las cualidades afiladas  
Placas embutidas no suporte para manter as propriedades de corte do dente  
Wkładki osadzone we wsporniku w celu utrzymania właściwości tnących zęba  
Integriert Platten in der Tragër für beibehalten die Schärfe Qualität*

- **Rechargement déposé avec précision et respect du support**

*A meticulous hardfacing  
Recargo cuidado  
Recarga depositada com precisão e respeito pelo suporte  
Przeładowanie zdeponowane z precyzją i poszanowaniem podłoża  
Akribische Hartmetall*

- **Cycle de brasage maîtrisé avec brasure à haute teneur d'argent**

*Specific brazing process  
Proceso de soldadura controlado  
Ciclo de brasagem controlado com liga de brasagem com elevado teor de prata  
Kontrolowany cykl lutowania ze stopem lutowniczym o wysokiej zawartości srebra  
Spezielles Lötverfahren*

- **Finition grenillée pour une meilleure présentation dans vos magasins**

*Sandblasted finition  
Acabado arenoso  
Acabamento jateado para uma melhor apresentação nas suas lojas  
Śrutowane wykończenie dla lepszej prezentacji w waszych sklepach  
Sandgestrahltes Endprodukt*



# PRÉPARATION DU SOL

🇬🇧 SOIL PREPARATION | 🇪🇸 PREPARACIÓN DEL SUELO | 🇵🇹 PREPARAÇÃO DO SOLO |  
🇵🇱 PRZYGOTOWANIE GLEBY | 🇩🇪 BODENVORBEREITUNG

## DEUX PLAQUETTES

Utilisation en sols décompactés peu profonds

2 plates - Shallow soil use  
2 placas - Utilización para suelo poco profundo  
2 placas - Utilização em solos pouco profundos e descompactados  
2 podkładki - Zastosowanie na płytkich, odspojonych glebach  
2 platten - Seicht boden Verwendung

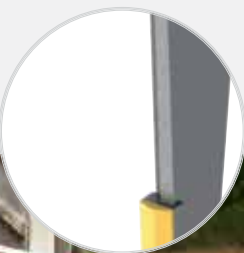

## TROIS PLAQUETTES

Utilisation en sols décompactés pour travaux profonds

3 plates - Deep soil use  
3 placas - Utilización para trabajos profundos  
3 placas - Utilização em solos descompactados para trabalhos profundos  
3 podkładki - Zastosowanie w luźnej glebie do głębokich prac  
3 platten - Tiefen boden Verwendung

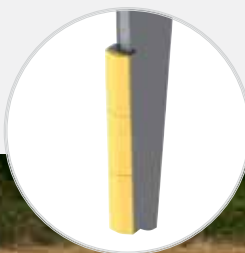

## ATTAQUANTES

Utilisation dans des sols non caillouteux  
Emiette très bien la terre

Grip - Rocky soil use  
Attacantes - Utilización para suelo pedregoso  
Atacantes - Utilizar em solos sem pedras, esfarela muito bem a terra  
Atakujący - Zastosowanie w glebie niezakamienionej, bardzo dobrze kruszy glebę  
Angreifer - Steiniger boden Verwendung

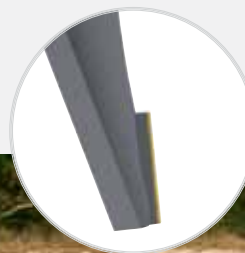

## FUYANTES

Utilisation courante évitant la remontée de cailloux

Drag - Common use  
Huidizas - Utilización frecuente  
Fugindo - Utilização de rotina para evitar que as pedras subam  
Uciekający - Rutynowe stosowanie w celu zapobiegania powstawania kamieni  
Fliehend - Übliche Verwendung



## RÉCHARGÉES



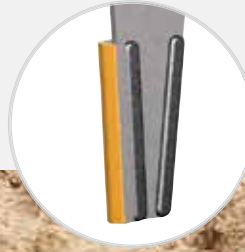

Option rechargement conseillée pour les dents vrillées

Hardfaced - Twisted point for hardfacing  
Racargadas - Opción recargo para punta retorcida  
Verschleiß - Verdreht Zinke









 **AGRI-POWER**

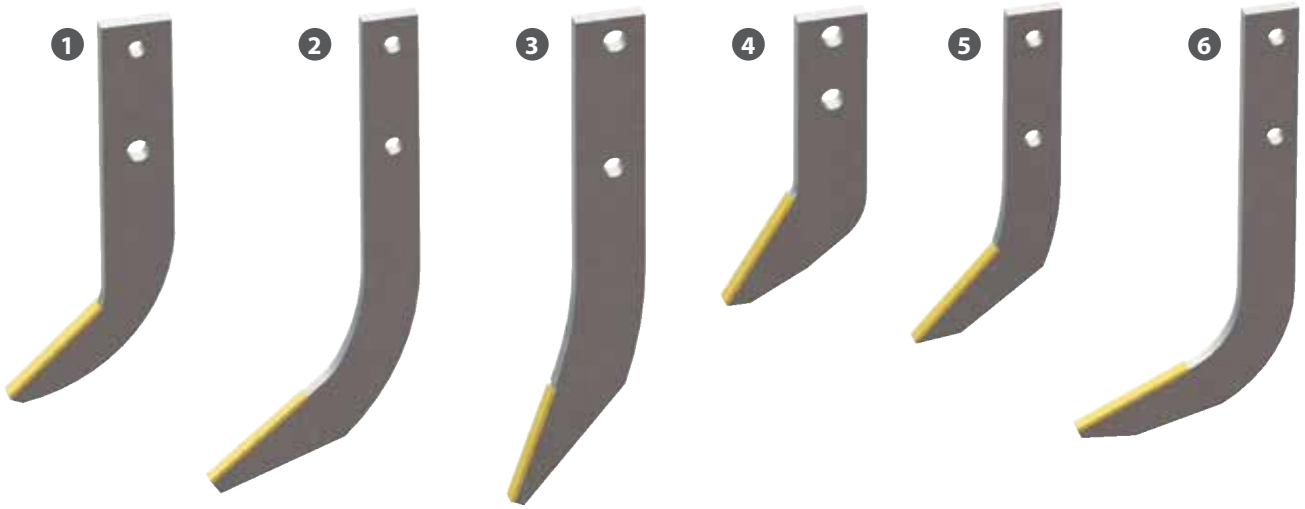

-  Ridger tines
-  Cuerpos de aporcador
-  Dentes de arado
-  Zęby spulchniacza
-  Fräshaken für dammfräse

## DENTS DE BUTTEUSES



-  Power harrow tines
-  Dientes de grada
-  Dentes de grade
-  Zęby brony aktywnej
-  Kreiseleggenzinken

## DENTS DE HERSES

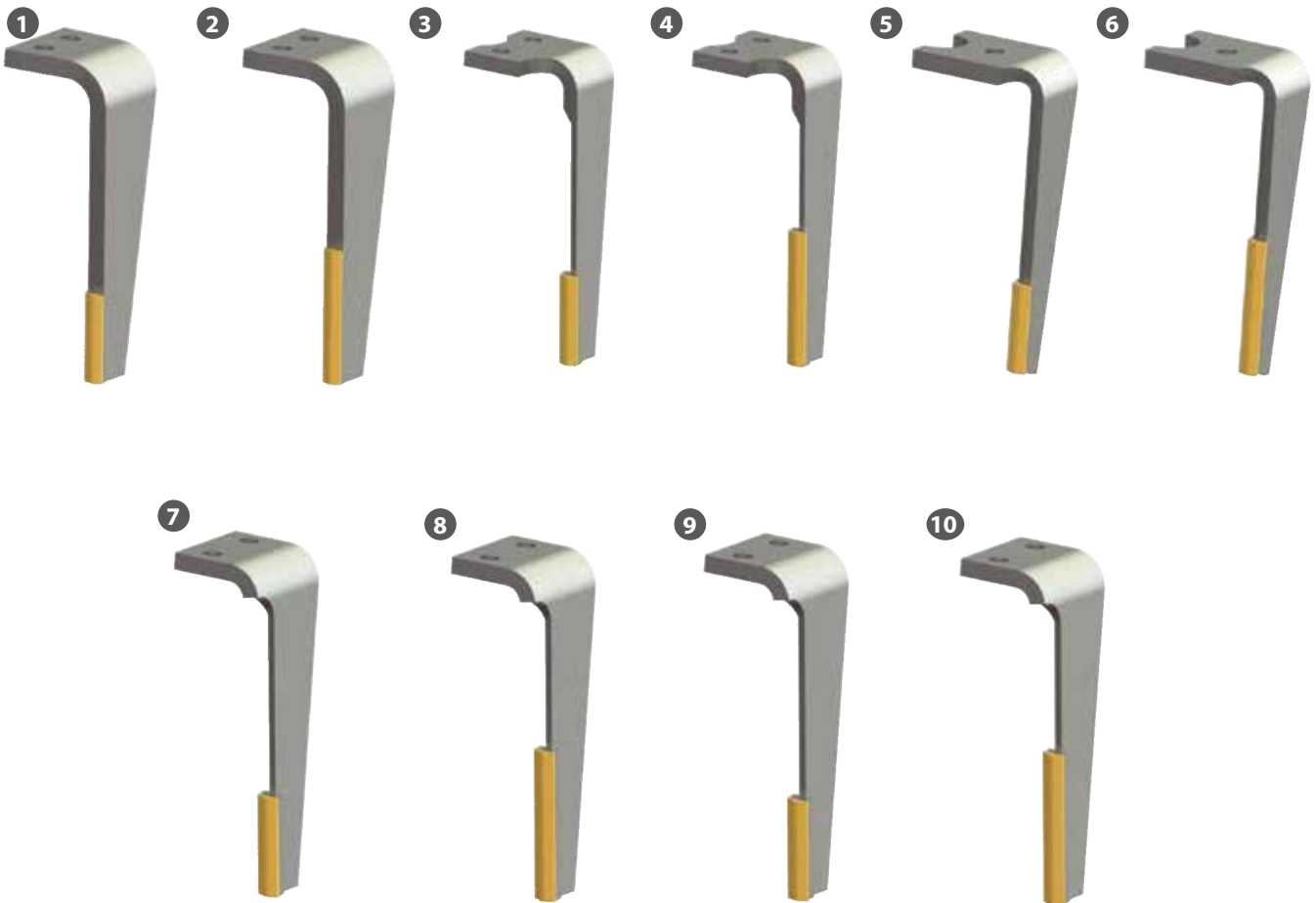





## DENTS DE BUTTEUSES

	Montage sur marques						Ref
	Type Para tipo Tipo Typ Passend zu						
1	<b>AVR</b>		1,24 kg	265 mm	12 mm	80 mm Ø 12 mm Ø 17 mm	<b>400849</b>
2	<b>BASELIER</b>		1,23 kg	360 mm	10 mm	80 mm Ø 12,5 mm	<b>209089</b>
3	<b>GRIMME</b>		1,62 kg	380 mm	12 mm	100 mm Ø 14,5 mm	<b>209090</b>
4			0,99 kg	220 mm	12 mm	50 mm Ø 16 mm	<b>400916</b>
5	<b>RUMPSTAD</b>		0,82 kg	255 mm	10 mm	80 mm Ø 12,5 mm	<b>209091</b>
6			1,21 kg	330 mm	10 mm	80 mm Ø 12,5 mm	<b>209092</b>

## DENTS DE HERSES

	Nombre Number Número Ilość Anzahl	Montage sur marques								OEM			OEM
		Type Para tipo Tipo Typ Passend zu											
1	2x	<b>AGRAM</b>	18 mm	1717388 TH 18 x 50	3,07 kg	50 mm Ø 19 mm	110 mm	325 mm	RH 85	<b>400759</b>	<b>400758</b>	RH 85	
2	3x		18 mm	1717388 TH 18 x 50	3,17 kg	50 mm Ø 19 mm	110 mm	325 mm	RH 85	<b>400761</b>	<b>400760</b>	RH 85	
3	2x	<b>ALPEGO</b>	18 mm	5905210 TH 16 x 60	3,20 kg	60 mm Ø 17 mm	110 mm	310 mm	D 07400	<b>400683</b>	<b>400682</b>	D 07401	
4	3x		18 mm	5905210 TH 16 x 60	3,30 kg	60 mm Ø 17 mm	110 mm	310 mm	D 07400	<b>400685</b>	<b>400684</b>	D 07401	
5	2x		15 mm	Rapide Fast-fit	2,50 kg	Ø 19 mm	100 mm	315 mm	D 05651	<b>400745</b>	<b>400744</b>	D 05650	
6	3x		15 mm	Rapide Fast-fit	2,60 kg	Ø 19 mm	100 mm	315 mm	D 05651	<b>400747</b>	<b>400746</b>	D 05650	
7	2x		14 mm	5905210 TH 16 x 60	2,50 kg	60 mm Ø 17 mm	100 mm	300 mm	D 06701	<b>400807</b>	<b>400806</b>	D 06701	
8	3x		14 mm	5905210 TH 16 x 60	2,60 kg	60 mm Ø 17 mm	100 mm	300 mm	D 06700	<b>400809</b>	<b>400808</b>	D 06700	
9	2x		12 mm	5905210 TH 16 x 60	2,05 kg	60 mm Ø 17 mm	100 mm	300 mm	D 06700	<b>209143</b>	<b>209142</b>	D 06700	
10	3x		12 mm	5905210 TH 16 x 60	2,15 kg	60 mm Ø 17 mm	100 mm	300 mm	D 06700	<b>209145</b>	<b>209144</b>	D 06700	

-  Power harrow tines
-  Dientes de grada
-  Dentes de grade
-  Zęby brony aktywnej
-  Kreiselegenzinken

# DENTS DE HERSES



1  
EA 140 mm  
ép : 15 mm  
Fuyante / Drag



2  
EA 140 mm  
ép : 15 mm  
Fuyante / Drag



3  
EA 140 mm  
ép : 15 mm  
Attaquante / Grip



4  
EA 140 mm  
ép : 15 mm  
Attaquante / Grip



**BEST SELLER**

5  
EA 147 mm  
ép : 15 mm  
Fuyante / Drag



**BEST SELLER**

6  
EA 147 mm  
ép : 15 mm  
Fuyante / Drag



**BEST SELLER**

7  
EA 147 mm  
ép : 15 mm  
Attaquante / Grip



**BEST SELLER**

8  
EA 147 mm  
ép : 15 mm  
Attaquante / Grip



9  
KE03  
ép : 18 mm  
Fuyante / Drag



10  
KE03  
ép : 18 mm  
Fuyante / Drag



11  
KE02  
ép : 15 mm  
Fuyante / Drag



12  
KE02  
ép : 15 mm  
Fuyante / Drag









## DENTS DE HERSES

1	Nombre Number Número Número Ilość Anzahl	Montage sur marques Type Para tipo Tipo Typ Passend zu							OEM			OEM
1	2x	AMAZONE	15 mm	5160114	3,65 kg	Ø 19 mm EA 140 mm	120 mm	330 mm	967496/ 6575300	209711	209710	967495/ 6574300
2	3x		15 mm	5160114	3,75 kg	Ø 19 mm EA 140 mm	120 mm	330 mm	967496/ 6575300	209713	209712	967495/ 6574300
3	2x		15 mm	5160114	3,65 kg	Ø 19 mm EA 140 mm	120 mm	330 mm	967496/ 6575300	209715	209714	967495/ 6574300
4	3x		15 mm	5160114	3,75 kg	Ø 19 mm EA 140 mm	120 mm	330 mm	967496/ 6575300	209717	209716	967495/ 6574300
5	2x		15 mm	5160114	3,65 kg	Ø 19 mm EA 147 mm	120 mm	330 mm	967496	400795	400794	967495
6	3x		15 mm	5160114	3,75 kg	Ø 19 mm EA 147 mm	120 mm	330 mm	967496	400797	400796	967495
7	2x		15 mm	5160114	3,65 kg	Ø 19 mm EA 147 mm	120 mm	330 mm	967496	400799	400798	967495
8	3x		15 mm	5160114	3,75 kg	Ø 19 mm EA 147 mm	120 mm	330 mm	967496	400801	400800	967495
9	2x		18 mm	5160114	3,10 kg	Ø 19 mm	60 mm	290 mm	954427	209119	209118	954426
10	3x		18 mm	5160114	3,20 kg	Ø 19 mm	60 mm	290 mm	954427	209121	209120	954426
11	2x		15 mm	5160114	2,65 kg	Ø 19 mm	60 mm	290 mm	950789	209204	209203	950788
12	3x		15 mm	5160114	2,75 kg	Ø 19 mm	60 mm	290 mm	950789	209206	209205	950788
13	2x		-	5905130 TH 12 x 45	2,15 kg	Ø 13 mm	-	312 mm	6302100	209416	209415	6303100
14	3x		-	5905130 TH 12 x 45	2,25 kg	Ø 13 mm	-	312 mm	6302100	209418	209417	6303100

## Montage des dents de herse

Power harrow tines assemble | Kreiseleggenzinken Montage | Montaje de las dientes de grada



































-  Power harrow tines
-  Dientes de grada
-  Dentes de grade
-  Zęby brony aktywnej
-  Kreiselegenzinken

# DENTS DE HERSES



## DENTS DE HERSES

	Nombre	Montage sur marques							OEM		OEM	
	Number Número Número Ilość Anzahl	Type Para tipo Tipo Typ Passend zu										
1	2x 	BREVIGLIERI	15 mm	Rapide Fast-fit	2,60 kg	Ø 32 mm	100 mm	300 mm	E0100130	400791	E0100129	400790
2	3x 		15 mm	Rapide Fast-fit	2,70 kg	Ø 32 mm	100 mm	300 mm	E0100130	400793	E0100129	400792
3	2x 	FALC	12 mm	5905210 TH 16 x 60	1,85 kg	50 mm Ø 17 mm	90 mm	285 mm	512076	209139	512075	209138
4	3x 		12 mm	5905210 TH 16 x 60	1,95 kg	50 mm Ø 17 mm	90 mm	285 mm	512076	209141	512075	209140
5	2x 	FERABOLI	15 mm	Rapide Fast-fit	3,40 kg	Ø 13 mm	110 mm	320 mm	7U0039	400741	7U0040	400740
6	3x 		15 mm	Rapide Fast-fit	3,50 kg	Ø 13 mm	110 mm	320 mm	7U0039	400743	7U0040	400742
7	2x 		12 mm	5905540 TH 16 x 60	2,05 kg	60 mm Ø 17 mm	100 mm	300 mm	7U00006	209143	7U00006	209142
8	3x 		12 mm	5905540 TH 16 x 60	2,15 kg	60 mm Ø 17 mm	100 mm	300 mm	7U00006	209145	7U00006	209144
9	2x 		15 mm	5905620 TH 20x55	3,18	60/20,5	110 mm	310 mm	7U0034	400755	7U0033	400754
10	3x 		15 mm	5905620 TH 20x56	3,28	60/20,6	110 mm	310 mm	7U0034	400757	7U0033	400756
11	2x 		15 mm	5905540 TH 16 x 60	2,83 kg	60 mm Ø 17 mm	100 mm	315 mm	185505	209131	185506	209130
12	3x 		15 mm	5905540 TH 16 x 60	2,93 kg	60 mm Ø 17 mm	100 mm	315 mm	185505	209133	185506	209132
13	2x 		15 mm	5905620 TH 20 x 55	2,71 kg	60 mm Ø 20 mm	100 mm	300 mm	185598	209135	185599	209134
14	3x 		15 mm	5905620 TH 20 x 55	2,81 kg	60 mm Ø 20 mm	100 mm	300 mm	185598	209137	185599	209136
15	2x 	HOWARD	15 mm	229008 TH 14 x 45	2,54 kg	60 mm Ø 14 mm	100 mm	315 mm	182939	209885	182940	209884
16	3x 		15 mm	229008 TH 14 x 45	2,64 kg	60 mm Ø 14 mm	100 mm	315 mm	182939	209887	182940	209886
17	2x 		15 mm	229008 TH 14 x 45	2,18 kg	60 mm Ø 14 mm	100 mm	265 mm	182935 182937	400777	182936 182938	400776
18	3x 		15 mm	229008 TH 14 x 45	2,28 kg	60 mm Ø 14 mm	100 mm	265 mm	182935 182937	400779	182936 182938	400778
19	2x 		15 mm	5905210 TH 16x60	2,35 kg	60/16,5	100 mm	275 mm	185515	400977	185516	400976
20	3x 		15 mm	5905210 TH 16x60	2,45 kg	60/16,5	100 mm	275 mm	185515	400979	185516	400978

-  Power harrow tines
-  Dientes de grada
-  Dentes de grade
-  Zęby brony aktywnej
-  Kreiselegenzinken

# DENTS DE HERSES



Support origine / Original tine    Support origine / Original tine    Support origine / Original tine    Support origine / Original tine    Support origine / Original tine    Support origine / Original tine







Support origine / Original tine    Support origine / Original tine    Support origine / Original tine    Support origine / Original tine    Support origine / Original tine



## DENTS DE HERSES

1	Nombre	Montage sur marques							OEM		OEM	
	Number Número Número Ilość Anzahl	Type Para tipo Tipo Typ Passend zu										
1	2x	KUH N	16 mm	5905210 TH 16 x 60	3,20 kg	68 mm Ø 17 mm	100 mm	300 mm	52539500 52556500	205349	52539400 52556400	205348
2	3x		16 mm	5905210 TH 16 x 60	3,30 kg	68 mm Ø 17 mm	100 mm	300 mm	52539500 52556500	205351	52539400 52556400	205350
3	2x		12 mm	5905210 TH 16 x 60	2,35 kg	68 mm Ø 17 mm	110 mm	280 mm	52549530	209111	52549430	209110
4	3x		12 mm	5905210 TH 16 x 60	2,45 kg	68 mm Ø 17 mm	110 mm	280 mm	52549530	209113	52549430	209112
5	2x		18 mm	Rapide Fast-fit	3,64 kg	Ø 19 mm	110 mm	318 mm	52596510	209115	52596410	209114
6	3x		18 mm	Rapide Fast-fit	3,70 kg	Ø 19 mm	110 mm	318 mm	52596510	209117	52596410	209116
7	2x		16 mm	Rapide Fast-fit	3,95 kg	Ø 19 mm	120 mm	310 mm	K2500090	205354	K25000100	205355
8	3x		16 mm	Rapide Fast-fit	4,05 kg	Ø 19 mm	120 mm	310 mm	K2500090	205356	K2500100	205357
7	2x		18 mm	Rapide Fast-fit	4,05 kg	Ø 20 mm	110 mm	338 mm	K2507080	415454	K2507070	415453
8	2x		18 mm	Rapide Fast-fit	4,15 kg	Ø 20 mm	110 mm	338 mm	K2507080	415456	K2507070	415455
9	2x		14 mm	Rapide Fast-fit	2,84 kg	Ø 19 mm	110 mm	290 mm	K2500071	205353	K2500081	205352
10	3x		16 mm	Rapide Fast-fit	4,05 kg	Ø 19 mm	120 mm	310 mm	K2500071	400753	K2500081	400752
11	2x		16 mm	Rapide Fast-fit	4,04 kg	Ø 19 mm	120 mm	315 mm	K2500130	209707	K2500120	209706
12	3x		16 mm	Rapide Fast-fit	4,14 kg	Ø 19 mm	120 mm	315 mm	K2500130	209709	K2500120	209708
13	2x		16 mm	Rapide Fast-fit	3,60 kg	Ø 19 mm	110 mm	318 mm	52597510	209703	52597410	209702
14	3x		16 mm	Rapide Fast-fit	3,70 kg	Ø 19 mm	110 mm	318 mm	52597510	209705	52597410	209704
15	2x		14 mm	5905210 TH 16 x 60	2,65 kg	68 mm Ø 17 mm	110 mm	340 mm	52552510	400607	52552410	400606
16	3x	14 mm	5905210 TH 16 x 60	2,75 kg	68 mm Ø 17 mm	110 mm	340 mm	52552510	400609	52554410	400608	
17	2x	14 mm	Rapide Fast-fit	3,90 kg	Ø 19 mm	110 mm	305 mm	52625500	209194	52625400	209193	

-  Power harrow tines
-  Dientes de grada
-  Dentes de grade
-  Zęby brony aktywnej
-  Kreiseleggenzinken

# DENTS DE HERSES

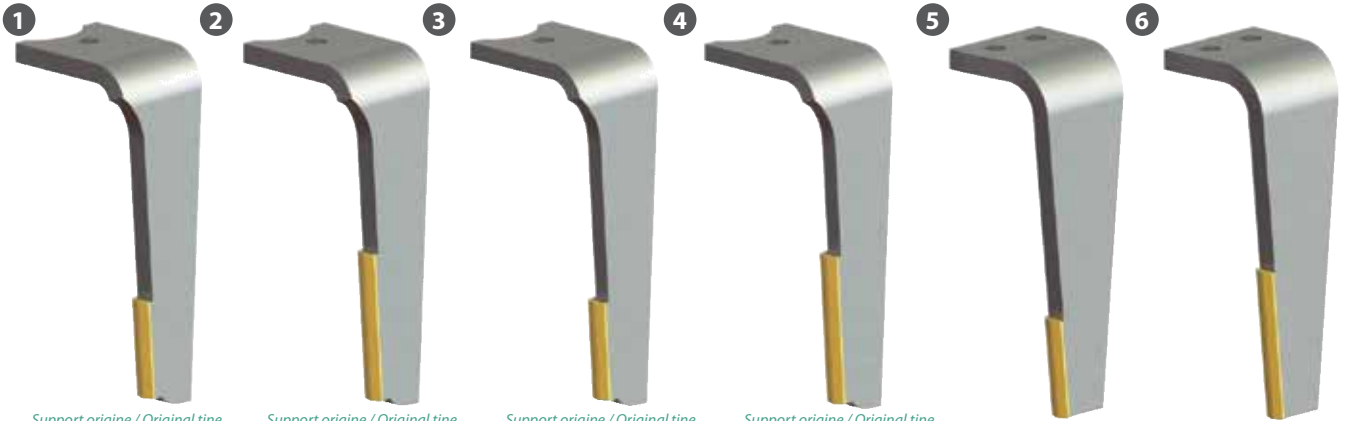

Support origine / Original tine

Support origine / Original tine

Support origine / Original tine

Support origine / Original tine

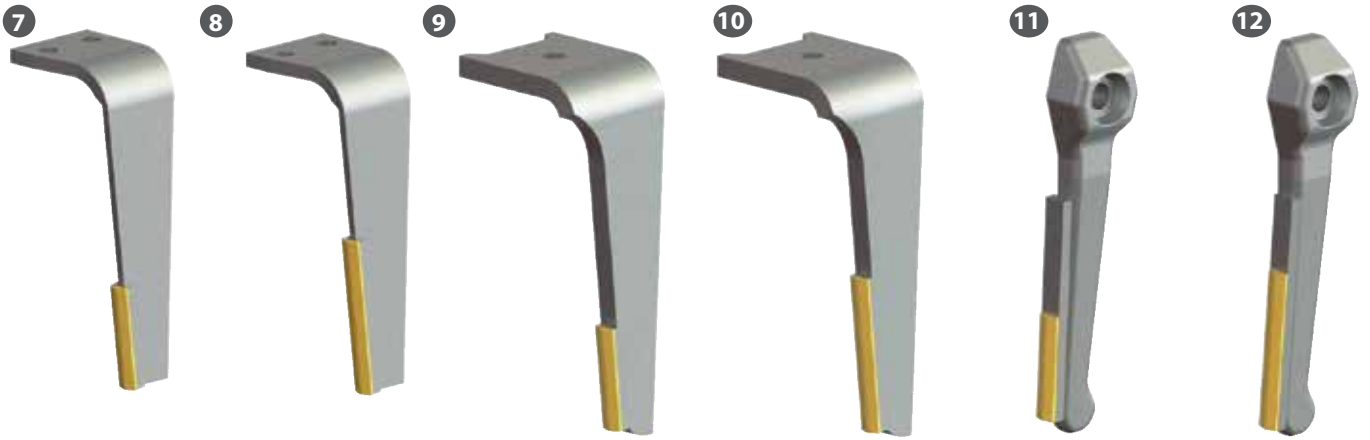

Support origine / Original tine

Support origine / Original tine



Support origine / Original tine

Support origine / Original tine





Support origine / Original tine

Support origine / Original tine



# DENTS DE HERSES

1	Nombre	Montage sur marques							OEM		OEM	
	Number Número Número Ilość Anzahl	Type Para tipo Tipo Typ Passend zu										
1	2x	KVERNELAND & MALETTI	18 mm	Rapide Fast-Fit	3,97 kg	Ø 19 mm	100 mm	330 mm	MA44000150	209127	MA44000151	209126
2	3x		18 mm	Rapide Fast-Fit	4,07 kg	Ø 19 mm	100 mm	330 mm	MA44000150	209129	MA44000151	209128
3	2x		15 mm	Rapide Fast-Fit	3,20 kg	Ø 18,5 mm	100 mm	330 mm	MA46000151	209699	MA46000150	209698
4	3x		15 mm	Rapide Fast-Fit	3,30 kg	Ø 18,5 mm	100 mm	330 mm	MA46000151	209701	MA46000150	209700
5	2x		18 mm	1717388 TH 18 x 50	3,07 kg	50 mm Ø 19 mm	110 mm	325 mm	MAE 040146	400759	MAE 030146	400758
6	3x		18 mm	1717388 TH 18 x 50	3,17 kg	50 mm Ø 19 mm	110 mm	325 mm	MAE 040146	400761	MAE 030146	400760
7	2x		12 mm	5905204 TH 16 x 50	1,76 kg	50 mm Ø 17 mm	90 mm	280 mm	MAE 020146	400763	MAE 010146	400762
8	3x		12 mm	5905204 TH 16 x 50	1,86 kg	50 mm Ø 17 mm	90 mm	280 mm	MAE 020146	400765	MAE 010146	400764
9	2x	LANDSBERG	18 mm	Rapide Fast-Fit	4,35 kg	Ø 26 mm	110 mm	320 mm	873402200	209831	873402250	209830
10	3x		18 mm	Rapide Fast-Fit	4,40 kg	Ø 26 mm	110 mm	320 mm	873402200	209833	873402250	209832
11	2x	LELY		1723201 257192	2,26 kg	Ø 22 mm	-	340 mm	116990111	209719	116990112	209718
12	3x			1723201 257192	2,36 kg	Ø 22 mm	-	340 mm	116990111	400631	116990112	400630
13	2x	LEMKEN	18 mm	-	3,45 kg	70 mm Ø 21 mm	110 mm	320 mm	3377033	400627	3377032	400626
14	3x		18 mm	-	3,55 kg	70 mm Ø 21 mm	110 mm	320 mm	3377033	400629	3377032	400628
15	2x		15 mm	5905210 TH 16 X 60	3,15 kg	72 mm Ø 17 mm	110 mm	320 mm	3377023	209147	3377022	209146
16	3x		15 mm	5905210 TH 16 x 60	3,25 kg	72 mm Ø 17 mm	110 mm	320 mm	3377023	209149	3377022	209148
17	2x			Rapide Fast-Fit	3,20 kg	-	100 mm	300 mm	3377059	209212	3377058	209211
18	3x			Rapide Fast-Fit	3,20 kg	-	100 mm	300 mm	3377059	209214	3377058	209213
19	2x			Rapide Fast-Fit	3,75 kg	-	100 mm	300 mm	3377049	209208	3377048	209207
20	3x			Rapide Fast-Fit	3,85 kg	-	100 mm	300 mm	3377049	209210	3377048	209209
21	2x			Rapide Fast-Fit	3,55 kg	-	100 mm	300 mm	33710011	400654	33710010	400653
22	3x			Rapide Fast-Fit	3,65 kg	-	100 mm	300 mm	33710011	400656	33710010	400655

-  Power harrow tines
-  Dientes de grada
-  Dentes de grade
-  Zęby brony aktywnej
-  Kreiselegenzinken

# DENTS DE HERSE











# DENTS DE HERSE

1	Nombre Number Número Número Ilość Anzahl	Montage sur marques Type Para tipo Tipo Typ Passend zu							OEM		OEM	
1	2x	MASHIO - BREVIGLIERI	12	5905210 TH 16 x 60	1,85 kg	50 mm Ø 17 mm	90 mm	285 mm	271002100 10100210	209139	27100209 10100209	209138
2	3x		12	5905210 TH 16 x 60	1,95 kg	50 mm Ø 17 mm	90 mm	285 mm	271002100 10100210	209141	27100209 10100209	209140
3	2x		12	5905210 TH 16 x 60	2,05 kg	60 mm Ø 17 mm	100 mm	300 mm	36100211	209143	36100210	209142
4	3x		12	5905210 TH 16 x 60	2,15 kg	60 mm Ø 17 mm	100 mm	300 mm	36100211	209145	36100210	209144
5	2x		15	Rapide Fast-Fit	3,60 kg	-	100 mm	320 mm	36100367	209399	36100366	209398
6	3x		15	Rapide Fast-Fit	3,70 kg	-	100 mm	320 mm	36100367	209401	36100366	209400
7	2x		15	5905210 TH 16 x 60	2,64 kg	60 mm Ø 17 mm	100 mm	300 mm	36100216 0088311	209597	36100215 0088310	209596
8	3x		15	5905210 TH 16 x 60	2,74 kg	60 mm Ø 17 mm	100 mm	300 mm	36100216 0088311	209599	36100215 0088310	209598
9	2x	MEKFOLD	15	Rapide Fast-fit	2,60 kg	Ø 32 mm	100 mm	300 mm	E0100130	400791	E0100129	400790
10	3x		15	Rapide Fast-fit	2,70 kg	Ø 32 mm	100 mm	300 mm	E0100130	400793	E0100129	400792
11	2x	PÖTTINGER	18	Rapide Fast-Fit	4,60 kg	-	110 mm	340 mm	873401200	209827	873401250	209826
12	3x		18	Rapide Fast-Fit	4,70 kg	-	110 mm	340 mm	873401200	209829	873401250	209828
13	2x		18	Rapide Fast-Fit	4,35 kg	Ø 26 mm	110 mm	320 mm	873402201 873402200	209831	873402251 873402250	209830
14	3x		18	Rapide Fast-Fit	4,40 kg	Ø 26 mm	110 mm	320 mm	873402201 873402200	209833	873402251 873402250	209832
15	2x	RABE	15	5905210 TH 16 x 60	2,67 kg	65 mm Ø 17 mm	110 mm	315 mm	84095002	205363	84095001	205362
16	3x		15	5905210 TH 16 x 60	2,77 kg	65 mm Ø 17 mm	110 mm	315 mm	84095002	205365	84095001	205364
17	2x		15	229008 TH 14 x 45	1,93 kg	40 mm Ø 15 mm	80 mm	310 mm	84091202	209123	84091201	209122
18	3x		15	229008 TH 14 x 45	2,03 kg	40 mm Ø 15 mm	80 mm	310 mm	84091202	209125	84091201	209124
19	2x		18	5905210 TH 16 x 60	3,01 kg	66 mm D 70 mm G Ø 17 mm	103 mm	310 mm	84231802	209154	84231801	209153
20	3x		18	5905210 TH 16 x 60	3,11 kg	66 mm D 70 mm G Ø 17 mm	103 mm	310 mm	84231802	400611	84231801	400610
21	2x		18	5905210 TH 16 x 60	3,01 kg	65 mm Ø 17 mm	100 mm	320 mm	84231803	400622	84231801	400621
22	3x		18	5905210 TH 16 x 60	3,11 kg	65 mm Ø 17 mm	100 mm	320 mm	84231803	400624	84231801	400623
23	2x	15	Rapide Fast-Fit	2,82 kg	-	100 mm	320 mm	84377702	209482	84377701	209481	
24	3x	15	Rapide Fast-Fit	2,92 kg	-	100 mm	320 mm	84377702	209484	84377701	209483	

-  Power harrow tines
-  Dientes de grada
-  Dentes de grade
-  Zęby brony aktywnej
-  Kreiselegenzinken

# DENTS DE HERSES



Support origine / Original tine

Support origine / Original tine

Support origine / Original tine

Support origine / Original tine



Support origine / Original tine

Support origine / Original tine





# DENTS DE HERSES

	Nombre Number Número Número Ilość Anzahl	Montage sur marques Type Para tipo Tipo Typ Passend zu							OEM		OEM	
1	2x	RAU	18	Rapide Fast-Fit	3,97 kg	Ø 19 mm	100 mm	330 mm	TT 2530	209127	TT 2530	209126
2	3x		18	Rapide Fast-Fit	4,07 kg	Ø 19 mm	100 mm	330 mm	TT 2530	209129	TT 2530	209128
3	2x		15	Rapide Fast-Fit	3,20 kg	Ø 18,5 mm	100 mm	330 mm	TT 1830	209699	TT 1830	209698
4	3x		15	Rapide Fast-Fit	3,30 kg	Ø 18,5 mm	100 mm	330 mm	TT 1830	209701	TT 1830	209700
5	2x		12	5905540 TH 16 x 60	1,85 kg	50 mm Ø 17 mm	90 mm	285 mm	44501	209139	44502	209138
6	3x		12	5905540 TH 16 x 60	1,95 kg	50 mm Ø 17 mm	90 mm	285 mm	44501	209141	44502	209140
7	2x	SULKY	18	-	3,01 kg	65 mm Ø 17 mm	100 mm	320 mm	980145 980132	400622	980146 980131	400621
8	3x		18	-	3,11 kg	65 mm Ø 17 mm	100 mm	320 mm	980145 980132	400624	980146 980131	400623
9	2x		18	Rapide Fast-Fit	3,50 kg	-	100 mm	330 mm	980309 980314	209216	980308 980315	209215
10	3x		18	Rapide Fast-Fit	3,60 kg	-	100 mm	330 mm	980309 980314	209218	980308 980315	209217
11	2x	SULKY (Cultiline 19/22/26/ 30/28/36)	18	Rapide Fast Fit	3,9 kg	-	100 mm	340 mm	980319	400981	980320	400980
12	3x		18	Rapide Fast Fit	4 kg	-	100 mm	340 mm	980319	400983	980320	400982
13	2x	TULIP	-	1723201 257192	2,26 kg	Ø 22 mm	-	340 mm	-	209719	-	209718
14	3x		-	1723201 257192	2,36 kg	Ø 22 mm	-	340 mm	-	400631	-	400630
5	2x	VICON	12	5905540 TH 16 x 60	1,85 kg	50 mm Ø 17 mm	90 mm	285 mm	7U 007 (master)	209139	7U 007 (master)	209138
6	3x		12	5905540 TH 16 x 60	1,95 kg	50 mm Ø 17 mm	90 mm	285 mm	7U 007 (master)	209141	7U 007 (master)	209140
15	2x		15	252647 TH 20x55	3,18	60/20,5	110	310	7U0034	400755	7U0033	400754
16	3x		15	252647 TH 20x56	3,28	60/20,6	110	310	7U0034	400757	7U0033	400756
5	2x	VÖGEL- NOOT	12	5905540 TH 16 x 60	1,85 kg	50 mm Ø 17 mm	90 mm	285 mm	50	209139	50	209138
6	3x		12	5905540 TH 16 x 60	1,95 kg	50 mm Ø 17 mm	90 mm	285 mm	50	209141	50	209140
17	2x		12	5905540 TH 16 x 60	2,05 kg	60 mm Ø 17 mm	100 mm	300 mm	60	209143	60	209142
18	3x		12	5905540 TH 16 x 60	2,15 kg	60 mm Ø 17 mm	100 mm	300 mm	60	209145	60	209144

## SUPPLÉMENT RECHARGEMENT With hardfacing bar | Mit Verschleißplatte | Con barra de recargo

Sur demande

Rep.	HAUTEUR Height   Höhe   Altura	REF.
19	2 x 90 mm	400867
20	2 x 135 mm	400868

-  Scrapers
-  Rascadores
-  Raspadores
-  Skrobaki
-  Abstreifer



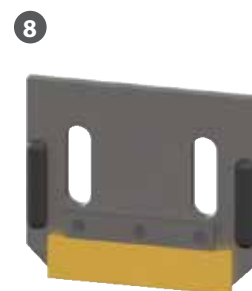

# GRATTOIRS







# GRATTOIRS

	Montage sur marques					OEM	Ref
	Type Para tipo Tipo Typ Passend zu						
1	<b>ALPEGO</b>	0,50 kg	150 mm	80 mm	5 mm	1308	<b>400834</b>
2	<b>AMAZONE</b>	0,50 kg	120 mm	90 mm	5 mm	6081200	<b>206216</b>
2	<b>FALC</b>	0,50 kg	120 mm	90 mm	5 mm	543001	<b>206216</b>
3	<b>GRAZIOLI-REMAC</b>	0,40 kg	100 mm	90 mm	9 mm	-	<b>209181</b>
4	<b>HOWARD</b>	0,40 kg	130 mm	100 mm	5 mm	652882	<b>209375</b>
6	<b>KUHN</b>	0,67 kg	170 mm	90 mm	5 mm	52598910	<b>209182</b>
6	<b>KVERNELAND</b>	0,67 kg	170 mm	90 mm	5 mm	8007090	<b>209182</b>
7	<b>LEMKEN</b>	0,40 kg	92,5 mm	90 mm	5 mm	3492004 34910019 34910020	<b>412451</b>
		0,50 kg	130 mm	90 mm	5 mm	3492001	<b>400716</b>
5	<b>PÖTTINGER</b>	0,50 kg	140 mm	75 mm	5 mm	435785	<b>206217</b>
6		0,67 kg	170 mm	90 mm	5 mm	435791	<b>209182</b>
8	<b>PERRUGINI</b>	0,40 kg	90 mm	100 mm	5 mm	-	<b>209184</b>
9	<b>PROSOL</b>	0,66 kg	170 mm	100 mm	5 mm	RU 05010010	<b>400842</b>
10	<b>RABE</b>	0,46 kg	120 mm	80 mm	5 mm	84050027	<b>209183</b>
8	<b>SULKY</b>	0,40 kg	90 mm	100 mm	5 mm	720345	<b>209184</b>
11	<b>VICON</b>	0,50 kg	125 mm	90 mm	5 mm	648921	<b>209185</b>

# APPORTEZ LA MEILLEURE SOLUTION AUX AGRICULTEURS

GIVE THE BEST SOLUTION TO FARMERS | SUMINISTRE LA MEJOR SOLUCIÓN A LOS AGRICULTORES | FORNECE A MELHOR SOLUÇÃO PARA OS AGRICULTORES | ZAPEWNIĆ ROLNIKOM NAJLEPSZE ROZWIĄZANIE | BRINGT DIE BESTE LÖSUNG FÜR DER LANDWIRTSCHAFT

## Standard Carbure

Standard carbure | Carbide standard | Carboneto padrão | Standardowy węgiel spiekany | Hartmetall Standard



<b>Investissement</b> Investment Inversión Investimento Investition inwestycja	+
<b>Durée</b> Lifetime Duracion Duração Trwanie Lebensdauer	+++
<b>Type de travaux</b> Type of work Tipo de trabajo Tipo de trabalho Rodzaj pracy Auftragstyp	Légers Light Ligero Luz Światło Leicht

### - Supports forgés sélectionnés

Forged support carefully selected  
Soporte forjado  
Soportes forjados seleccionados  
Wybrane kute wsporniki  
Geschmiedete Unterstützung

### - Plaquettes haute qualité

High quality plates  
Placas alta calidad  
Plaquetas de alta qualidade  
Wysokiej jakości podkładki  
Hohe Qualität Platten

### - Brasure haute teneur d'argent

High-grade silver brazing  
Soldadura con alta cantidad de plata  
Brasagem com elevado teor de prata  
Lut o wysokiej zawartości srebra  
Lötverfahren mit hohem Silbergehalt

## Standard Carbure + Rechargement

Standard carbure + hardfacing | Carbide standard + hardmetall | Hartmetall Standard + recargo



<b>Investissement</b> Investment Inversión Investimento Investition inwestycja	++
<b>Durée</b> Lifetime Duracion Duração Trwanie Lebensdauer	++++
<b>Type de travaux</b> Type of work Tipo de trabajo Tipo de trabalho Rodzaj pracy Auftragstyp	Légers Light Ligero Luz Światło Leicht

### - Supports forgés sélectionnés

Forged support carefully selected  
Soporte forjado  
Soportes forjados seleccionados  
Wybrane kute wsporniki  
Geschmiedete Unterstützung

### - Plaquettes haute qualité

High quality plates  
Placas alta calidad  
Plaquetas de alta qualidade  
Wysokiej jakości podkładki  
Hohe Qualität Platten

### - Brasure haute teneur d'argent

High-grade silver brazing  
Soldadura con alta cantidad de plata  
Brasagem com elevado teor de prata  
Lut o wysokiej zawartości srebra  
Lötverfahren mit hohem Silbergehalt

### - Rechargement qui protège les zones les plus sollicitées

Protective hardfacing  
Recargo protectorio  
Recargamento que protege as zonas mais utilizadas  
Przeladowywanie w celu ochrony najbardziej obciążonych obszarów  
Schutzhartmetall

### - Optimisation des plaquettes

Plates optimisation  
Optimización de las placas  
Otimização de plaquetas  
Optymalizacja podkładek  
Plattenoptimierung

## Heavy Duty



<b>Investissement</b> Investment Inversión Investimento Investition inwestycja	+++
<b>Durée</b> Lifetime Duracion Duração Trwanie Lebensdauer	+++++
<b>Type de travaux</b> Type of work Tipo de trabajo Tipo de trabalho Rodzaj pracy Auftragstyp	Très lourds Heavy Duty

### - Supports forgés spécialement pour maîtriser l'usure de la pointe

Especially forged supports to control the point wear  
Soportes especialmente forjados para controlar el desgaste de las puntas  
Soportes especialmente forjados para controlar o desgaste da ponta  
Specjalnie kute wsporniki kontrolujące zużycie końcówki  
Insbesondere Geschmiedete Unterstützung die Verschleiß zu meistern

### - Système auto-affûtant permettant une usure en pointe et facilitant ainsi la pénétration en sols secs

Self-sharpening system  
Sistema auto-filando  
System samoostrzenia zapewniający maksymalne zużycie  
Sistema de auto-afiamento para um desgaste em ponta  
Selbstschärfend System

### - Plaquette spécifique "long life"

"Long life" specific plate  
Placa específica "Long life"  
Plaqueta específica "longa duração"  
Specjalna podkładka "długa żywotność"  
Spezifischplatte "Long life"







# DÉCHAUMAGE

 STUBBLE PLOUGHING |  ARADA DE RASTROJO |  LAVOURA DE RESTOLHO |  
 ORKA ŚCIERNISKOWA |  STOPPELBEARBEITUNG



 **AGRI-POWER**





-  Cultivator points
-  Rejas de cultivador
-  Bicos de cultivadores
-  Lemiesze kultywatorów
-  Kultivatorschare





# SOCS DE CULTIVATEURS



# SOCS DE CULTIVATEURS

	Montage sur marques	Rechargement	Dimensions				Ref.
	Type Para tipo Tipo Typ Passend zu	Hardfacing Recargo Recarga Przeladowywanie Hartmetall Ausschweißen	Dimension Dimensiones Dimensões Wymiary Abmessungen				
1	UNIVERSEL		310 x 40 x 17 mm	5915235 TFCC 12 x 55	1,40 kg	40 - 60 mm Ø 12 mm	206218
2		✓		5915235 TFCC 12 x 55	1,45 kg		209195
3			360 x 50 x 20 mm	5915235 TFCC 12 x 55	2,40 kg	45 - 85 mm Ø 12 mm	206193
4		✓		5915235 TFCC 12 x 55	2,45 kg		400618
5		✓		5915235 TFCC 12X55	2,65 kg		400730
6			360 x 60 x 20 mm	5915235 TFCC 12 x 55	2,90 kg	45 - 85 mm Ø 12 mm	217960
7		✓		5915235 TFCC 12 x 55	2,95 kg		219581
8		✓		5915235 TFCC 12 x 55	3,00 kg		209196
9		<b>HEAVY DUTY</b>	360 x 60/70 x 20 mm	5915235 TFCC 12 x 55	3,12 kg	45 - 85 mm Ø 12 mm	209186
10		✓		5915235 TFCC 12X55	3,40 kg		412473
11		✓		5915235 TFCC 12X55	3,09 kg		413509
12		<b>HEAVY DUTY</b>	400 x 70 x 20 mm	5915235 TFCC 12X55	3,41 kg	45 - 85 mm Ø 14 mm	400938
13				5915250 TFCC 12 x 80	4,40 kg		217961
14				5915582 TFCC 14 x 90	4,35 kg		217962
15		✓	400 x 70 x 20 mm	5915250 TFCC 12 x 80	4,45 kg	45 - 85 mm Ø 12 mm	219582
16		✓		5915582 TFCC 14 x 90	4,40 kg		219583
17		✓		5915250 TFCC 12 x 80	4,50 kg		209197
18		✓	410 x 100 x 20 mm	5915582 TFCC 14 x 90	4,45 kg	45 - 85 mm Ø 14 mm	209198
19		<b>HEAVY DUTY</b>		5915250 TFCC 12 x 80	5,18 kg		400822
20			420 x 100 x 20 mm	5915250 TFCC 12 x 80	6,60 kg	45 - 85 mm Ø 12 mm	206221
21		✓		5915250 TFCC 12 x 80	6,65 kg		209445
22			410 x 120 x 20 mm	5915250 TFCC 12 x 80	6,30 kg	45 - 85 mm Ø 14 mm	206222
23		✓		5915250 TFCC 12 x 80	6,35 kg		209451
24				5915582 TFCC 14 x 90	6,30 kg		209454
25		✓	330 x 70 x 15 mm	5915582 TFCC 14 x 90	6,35 kg	45 - 85 mm Ø 12 mm	209455
26		<b>HEAVY DUTY</b>		5915235 TFCC 12 x 55	2,90 kg		219165
27		<b>HEAVY DUTY</b>	330 x 80 x 15 mm	5915235 TFCC 12 x 55	4,70 kg	205245	
28			170 x 115 x 20 mm	-	2,00 kg	-	400709











-  Cultivator points
-  Rejas de cultivador
-  Bicos de cultivadores
-  Lemiesze kultywatorów
-  Kultivatorschare

# SOCS DE CULTIVATEURS



# SOCS DE CULTIVATEURS

	Montage sur marques	Rechargement	Dimensions				OEM	Ref
	Type Para tipo Tipo Typ Passend zu	Hardfacing Recargo Recarga Przeladowywanie Hartmetall Ausschweißen	Dimension Dimensiones Dimensões Wymiary Abmessungen					
1	<b>AGRISEM</b>		250 x 70 x 20 mm	5915555 TFCC 12 x 90	3,40 kg	48 mm Ø 12 mm	AU2065 1103622/551	<b>400680</b>
2		✓		5915555 TFCC 12 x 90	3,45 kg	48 mm Ø 12 mm	AU 2065	<b>400681</b>
3			258 x 120 x 20 mm	5915555 TFCC 12 x 90	4,60 kg	48 mm Ø 12 mm	AU 2065	<b>400678</b>
4		✓		5915555 TFCC 12 x 90	4,70 kg	48 mm Ø 12 mm	AU 2065	<b>400679</b>
5	<b>CENIUS AMAZONE (Pégasus)</b>		200 x 120 x 20 mm	5915220 TFCC 12 x 40	3,02 kg	Ø 12 mm	XL 0018	<b>206220</b>
6		<b>HEAVY DUTY</b>	299 x 80 x 25 mm	-	3,70 kg	-	-	<b>451350</b>
7	<b>BEDNAR (Fénix)</b>		260 x 80 x 18 mm	5915555 TCC 12 x 90	2,03 kg	Ø 12 mm	KM 60334	<b>206219</b>
8		✓		5915555 TFCC 12 x 90	2,13 kg	Ø 12 mm		<b>209190</b>
9			260 x 80 x 20 mm	5915555 TFCC 12 x 90	2,55 kg	Ø 12 mm		<b>209191</b>
10		✓		5915555 TFCC 12 x 90	2,70 kg	Ø 12 mm		<b>209850</b>
11		<b>HEAVY DUTY</b>	265 x 80 x 28 mm	5915555 TFCC12 x 90	4,30 kg	55 mm Ø 12 mm		<b>400723</b>
12	<b>BOURBONNAIS FRAISSE</b>		370 x 80 x 20 mm	594 5900 TFCC 12X60	4,4	65 mm Ø 12 mm	-	<b>400941</b>
13		✓		594 5900 TFCC 12X60	4,6	65 mm Ø 12 mm	-	<b>400942</b>
7	<b>HORSCH (Terrano)</b>		260 x 80 x 18 mm	5915555 TCC 12 x 90	2,03 kg	Ø 12 mm	340.60.850 00311069	<b>206219</b>
8		✓		5915555 TFCC 12 x 90	2,13 kg	Ø 12 mm	340.60.850 00311069	<b>209190</b>
9			260 x 80 x 20 mm	5915555 TFCC 12 x 90	2,55 kg	Ø 12 mm	340.60.850 00311069	<b>209191</b>
10		✓		5915555 TFCC 12 x 90	2,70 kg	Ø 12 mm	340.60.850 00311069	<b>209850</b>
11		<b>HEAVY DUTY</b>	265 x 80 x 28 mm	5915555 TFCC 12 x 90	4,30 kg	Ø 12 mm	340.60.850 00311069	<b>400723</b>
14		<b>HEAVY DUTY</b>		5915235 TFCC 12X55	4,90 kg	57 mm Ø 12 mm	340.60.850 00311069	<b>400935</b>
15		<b>HEAVY DUTY</b>	LOW DISTURBANCE 477 x 40 x 20 mm	5915555 TFCC 12 x 90	3,00 kg	57 mm Ø 12 mm	00311113	<b>400785</b>
16		<b>HEAVY DUTY</b>	LOW DISTURBANCE 477 x 50 x 25 mm	5915555 TFCC 12X90	5,40 kg	57 mm Ø 12 mm	00311113	<b>400990</b>
17		<b>HEAVY DUTY</b>	ULD 446 x 60 x 135 mm	5915555 TFCC 12X90	5,40 kg	-	241.52.200	<b>400984</b>
18		<b>HEAVY DUTY</b> ✓	499 x 46 x 174 mm	5915555 TFCC 12X90	6,35 kg	58,5 Ø 13 mm	00311357	<b>451322</b>
10		<b>ILGI (Apollo)</b>	✓	260 x 80 x 20 mm	5915555 TFCC 12 x 90	2,70 kg	Ø 12 mm	340.60.850
11	<b>HEAVY DUTY</b>		265 x 80 x 28 mm	5915555 TFCC 12 x 90	4,30 kg	Ø 12 mm	10300110 10300120	<b>400723</b>
10	<b>JEAN DE BRU (Néotiller, Maxitiller, Vakitiller)</b>	✓	260 x 80 x 20 mm	5915555 TFCC 12 x 90	2,70 kg	Ø 12 mm	340.60.850	<b>209850</b>
11		<b>HEAVY DUTY</b>	265 x 80 x 28 mm	5915555 TFCC 12 x 90	4,30 kg	Ø 12 mm	1191201 1191211	<b>400723</b>





-  Cultivator points
-  Rejas de cultivador
-  Bicos de cultivadores
-  Lemieszki kultywatorów
-  Kultivatorschare

# SOCS DE CULTIVATEURS



# SOCs DE CULTIVATEURS

	Montage sur marques	Rechargement	Dimensions				OEM	Ref
	Type Para tipo Tipo Typ Passend zu	Hardfacing Recargo Recarga Przetadowywanie Hartmetall Ausschweißen	Dimension Dimensiones Dimensões Wymiary Abmessungen					
1	<b>KIRPY</b> (Culti-lourd non-stop)		360 x 60 x 20 mm	-	2,95 kg	74 mm Ø 16 mm	02.09.3032	400668
2		✓		-	3,00 kg	74 mm Ø 16 mm	02.09.3032	400669
3	<b>KÖCKERLING</b> (Quadro / Vector / Topmix / Trio)		260 x 80 x 18 mm	5915555 TFCC 12 x 90	2,40 kg	Ø 12 mm	506065	400641
4		✓		5915555 TFCC 12 x 90	2,45 kg	Ø 12 mm	506065	400642
5			285 x 80 x 15 mm	5915555 TFCC 12 x 90	2,00 kg	Ø 12 mm	506065	209692
6		✓		5915555 TFCC 12 x 90	2,10 kg	Ø 12 mm	506065	209693
7		<b>HEAVY DUTY</b>		5915555 TFCC 12 x 90	4,30 kg	Ø 12 mm	915776	400721
8	<b>KONGSKILDE</b> (Deltaflex)		270 x 80 x 20 mm	5915555 TFCC 12 x 90	3,15 kg	Ø 12 mm	101003120	400714
9		✓		5915555 TFCC 12 x 90	3,20 kg	Ø 12 mm	101003120	400715
10	<b>KUHN</b> (Cultimer)	<b>HEAVY DUTY</b>	275 x 80 x 20 mm	5915555 TFCC 12 x 90	3,11 kg	45 mm Ø 12 mm	2220760 2212540 2217920	400828
11	<b>KVERNELAND</b> (CLC / CTC)		220 x 70 x 20 mm	5940265 TC2M 12 x 50	2,31 kg	40 mm Ø 12 mm	KK053090	209231
12		✓		5940265 TC2M 12 x 50	2,38 kg	40 mm Ø 12 mm	KK053090	209232
13	<b>LEMKEN</b> (Kara Kristall)		240 x 80 x 18 mm	5915250 TCC 12 x 80	2,05 kg	Ø 12 mm	3374441	400710
14		✓		5915250 TFCC 12 x 80	2,10 kg	Ø 12 mm	3374441	400711
15			240 x 80 x 20 mm	5915250 TFCC 12 x 80	2,75 kg	Ø 12 mm	3374441	400712
16		✓		5915250 TFCC 12 x 80	2,80 kg	Ø 12 mm	3374441	400713
17		<b>HEAVY DUTY</b>		230 x 120 x 20 mm	5915250 TFCC 12 x 80	3,80 kg	Ø 12 mm	3374442 / 43
18	<b>LEMKEN</b> (Smaragd)		200 x 120 x 20 mm	5915220 TFCC 12 x 40	3,02 kg	Ø 12 mm	3374388	206220
19			450 x 80 x 15 mm	5915250 TFCC 12 x 80	4,50 kg	Ø 12 mm	3374438	206192
18	<b>MASCHIO</b> (Terre moto)		200 x 120 x 20 mm	5915220 TFCC 12 x 40	3,02 kg	Ø 12 mm	F20100026	206220
11	<b>OVLAC / ESCUADERO</b> (Versatil)		220 x 70 x 20 mm	5940265 TC2M 12 x 50	2,31 kg	40 mm Ø 12 mm	1664000033	209231
12		✓		5940265 TC2M 12 x 50	2,38 kg	40 mm Ø 12 mm	1664000034	209232
20	<b>POTTINGER</b>		260 x 80 x 20 mm	5915545 TFCC 12X70	3,07 kg	45 mm Ø 12 mm	9762500151	412466
21		✓		5915545 TFCC 12X70	3,13 kg	45 mm Ø 12 mm	9762500151	412467
22		<b>HEAVY DUTY</b>	5915545 TFCC 12X70	4,57 kg	45 mm Ø 12 mm	9762500151	400943	
23		<b>HEAVY DUTY</b>	428 x 58 x 125 mm	594 5900 TFCC 12X60	5,70 kg	46/59 mm Ø 13 mm	-	400985

-  Cultivator points
-  Rejas de cultivador
-  Bicos de cultivadores
-  Lemiesze kultywatorów
-  Kultivatorschare

# SOCS DE CULTIVATEURS



1



2



3



4



5



6

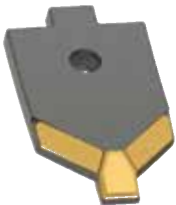

7



8



9



10



11



12



13



14



15



16



17



18



19







20





# SOCS DE CULTIVATEURS

	Montage sur marques	Rechargement	Dimensions				OEM	Ref
	Type Para tipo Tipo Typ Passend zu	Hardfacing Recargo Recarga Przeladowywanie Hartmetall Auschweißen	Dimension Dimensiones Dimensões Wymiary Abmessungen					
1	<b>QUIVOGNE</b> (NSL) (DOUBLE COEUR) (BLACK BEAR)	✓	220 x 70 x 20 mm	5940265 TC2M 12 x 50	2,38 kg	40 mm Ø 12 mm	Soc 20061G/51D	209232
2		<b>HEAVY DUTY</b>	410 x 100 x 20 mm	5915250 TFCC 12 x 80	5,18 kg	45-85 mm Ø 12 mm	Universel	400822
3		✓	260 x 80 x 20 mm	5915555 TFCC 12 x 90	2,65 kg	Ø 12 mm	Soc 21301	209192
4		<b>HEAVY DUTY</b>	265 x 80 x 28 mm	5915555 TFCC 12 x 90	4,30 kg	Ø 12 mm	Soc 21301	400723
5	<b>RAZOL</b> (Aramix, Kos)	<b>HEAVY DUTY</b>	200 x 100 x 20 mm	5915555 TFCC 12 x 90	2,39 kg	Ø 12 mm	3488	400835
6	<b>SOUCHU PINET</b> (CTM)		200 X 120 X 20	5915220 TFCC 12 x 40	3,02 kg	Ø 12 mm	10226	206220
7	<b>SKY</b> (DDE)	<b>HEAVY DUTY</b>	230 x 120 x 20 mm	5915250 TFCC 12 x 80	3,80 kg	Ø 12 mm	50316901	400737
8	<b>UNIA</b> (Kos)		258 x 120 x 20 mm	5915220 TFCC 12 x 40	4,60 kg	70 mm Ø 12 mm	AP 701	400678
9		✓		5915220 TFCC 12 x 40	4,70 kg	70 mm Ø 12 mm	AP 701	400679
10	<b>UNIA</b> (Cross)		250 x 70 x 20 mm	5915555 TFCC 12 x 90	3,40 kg	48 mm Ø 12 mm	AU 2065	400680
11		✓		5915555 TFCC 12 x 90	3,45 kg	48 mm Ø 12 mm	AU 2065	400681
12	<b>VÄDERSTAD</b> (Swift / Cultus / (Topdown)		240 x 80 x 20 mm	5915250 TFCC 12 x 80	3,10 kg	Ø 12 mm	452854	400643
13		✓		5915250 TFCC 12 x 80	3,15 kg	Ø 12 mm	452854	400644
14			260 x 80 x 20 mm	5915220 TFCC 12 x 40	3,15 kg	30 mm Ø 12 mm	489233-1	400645
15		✓		5915220 TFCC 12 x 40	3,20 kg	30 mm Ø 12 mm	489233-1	400646
16			260 x 50 x 20 mm	5915220 TFCC 12 x 40	2,10 kg	30 mm Ø 12 mm	488441-1	400647
17		✓		5915220 TFCC 12 x 40	2,15 kg	30 mm Ø 12 mm	488441-1	400648
18			425 x 50 x 20 mm	5915545 TFCC 12X70	3,50 kg	55 mm Ø 12 mm	473698-1	400823
19		✓		5915545 TFCC 12X70	3,55 kg	55 mm Ø 12 mm	473698-1	400824
20		<b>HEAVY DUTY</b>		5915545 TFCC 12X70	3,20 kg	55 mm Ø 12 mm	473698-1	400858



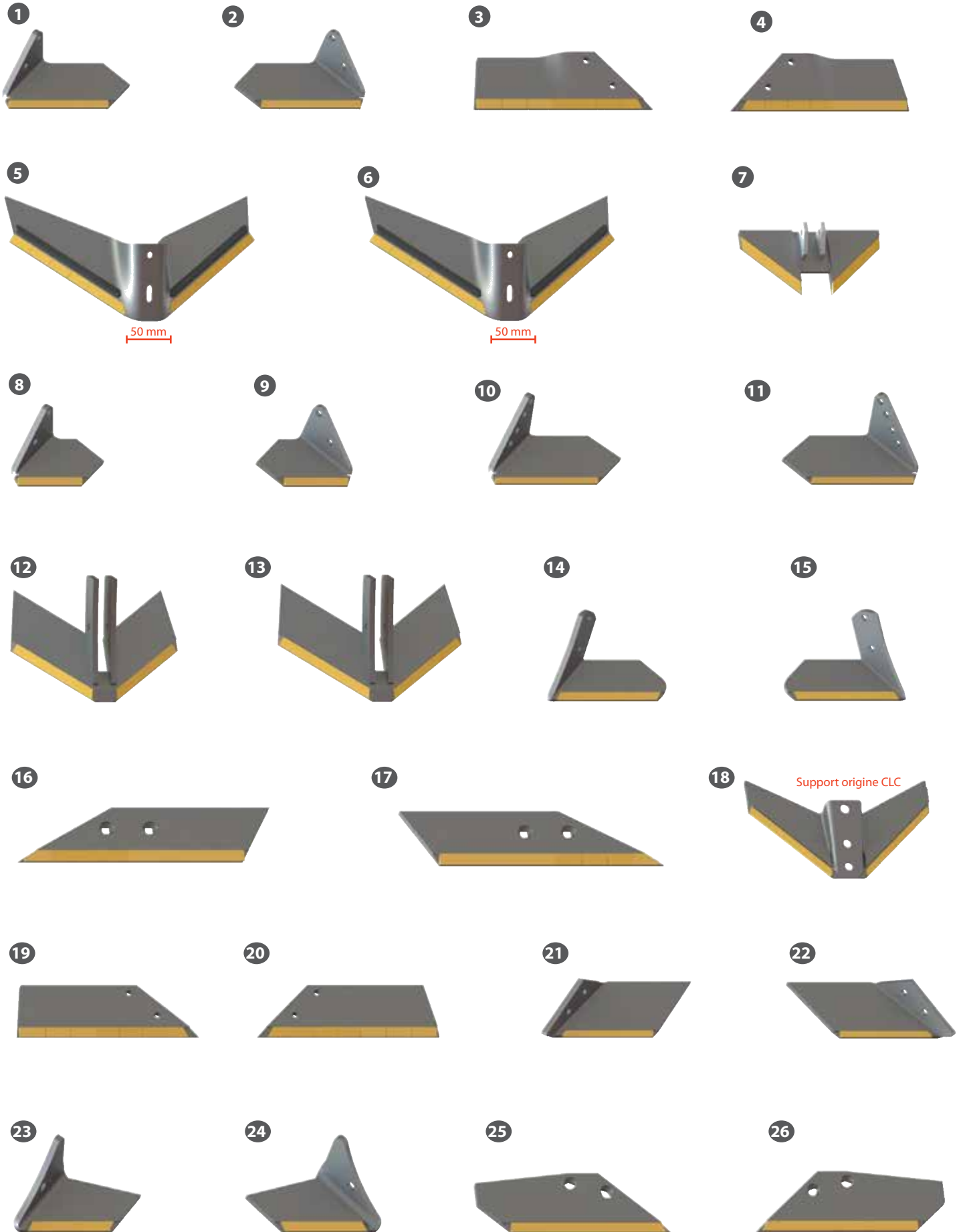

-  Cultivator points
-  Rejas de cultivador
-  Bicos de cultivadores
-  Lemiesze kultywatorów
-  Kultivatorschare

# AILERONS DE CULTIVATEURS



# AILERONS DE CULTIVATEURS







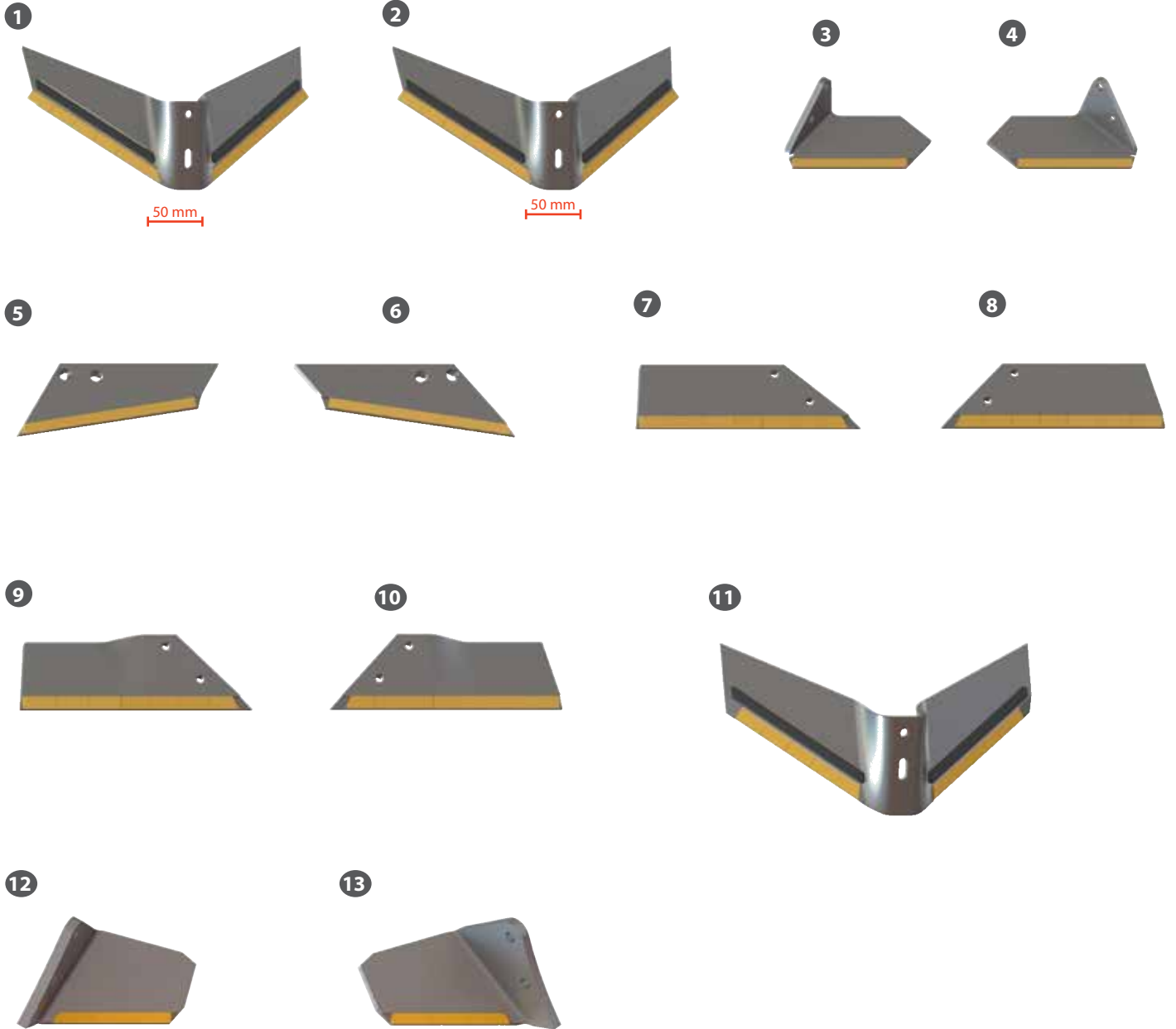

		Montage sur marques										
		Type Para tipo Typo Typ Passend zu							OEM			OEM
1 2	<b>ALPEGO</b> (Pama)	1717263 TH 12 x 70	2,43 kg	60 mm Ø 12 mm	200 mm	100 mm	12 mm	D 16602	<b>209372</b>	<b>209371</b>	D 16601	
3 4	<b>AMAZONE</b> (Pegasus)	-	3,52 kg	70 mm Ø 12 mm	360 mm	110 mm	14 mm	XL 005	<b>206226</b>	<b>206225</b>	XL 004	
1 2	<b>BREMER</b> (Champion)	1717263 TH 12 x 70	2,43 kg	60 mm Ø 12 mm	200 mm	100 mm	12 mm	-	<b>209372</b>	<b>209371</b>	-	
5	<b>FARMET</b> (Champion)	5915250 TFCC 12 x 80	7,7 kg	45/75 mm 12 mm	480 mm	100 mm	12 mm	GX 460 NS	<b>206227</b>		-	
7	<b>GRÉGOIRE-BESSON</b> (Discodent)	-	2,62 kg	-	280 mm	-	-	107 802 500/ 107 803 700	<b>400874</b>	<b>400874</b>	107 802 500/ 107 803 700	
1 2	<b>HORSCH</b> (Terrano) (Tiger)	1717263 TH 12 x 70	2,43 kg	60 mm Ø 12 mm	200 mm	100 mm	12 mm	34060857	<b>209372</b>	<b>209371</b>	34060856	
8 9		1717263 TH 12 x 70	1,62 kg	60 mm Ø 12 mm	125 mm	100 mm	12 mm	34060855	<b>400844</b>	<b>400843</b>	34060854	
10 11		1717263 TH 12 x 70	2,40 kg	-	200 mm	100 mm	12 mm	34060856 0311274	<b>400922</b>	<b>400921</b>	34060857 0031127	
1 2	<b>ILGI</b> (Apollo)	1717263 TH 12 x 70	2,43 kg	60 mm Ø 12 mm	200 mm	100 mm	12 mm	-	<b>209372</b>	<b>209371</b>	-	
1 2	<b>JEAN DE BRU</b>	1717263 TH 12 x 70	2,43 kg	60 mm Ø 12 mm	200 mm	100 mm	12 mm	-	<b>209372</b>	<b>209371</b>	-	
12	<b>KOCKERLING</b> (Trio/Quadro)	-	6 kg	14 mm	357 mm	-	12 mm	506015	<b>400875</b>		-	
13		-	6 kg	14 mm	390 mm	-	12 mm	506025	<b>400876</b>		-	
6	<b>KUHN</b> (Cultimer)	1717263 TH 14 x 90	7,7 kg	45/75 mm 14 mm	480 mm	100 mm	12 mm	7002	<b>206228</b>		-	
14 15		225950 TFCC 12x70	2,30 kg		245 mm	95 mm	12 mm	H2218181	<b>412458</b>	<b>412457</b>	H2218180	
16 17	<b>KVERNELAND</b> (CLD) (CLC)	5915220 TFCC 12 x 40	3,05 kg	75 mm Ø 12 mm	390 mm	100 mm	12 mm	131126	<b>400650</b>	<b>400649</b>	131125	
18		5940332 TC2M 14 x 34	1,78 kg	14 mm	300 mm	125 mm	10 mm	KK301123	<b>209457</b>		-	
3 4	<b>LEMKEN</b> (Smaragd) (Karat)	5940344 TRCC 12 x 30	3,52 kg	70 mm Ø 12 mm	360 mm	110 mm	14 mm	3374421 3374417	<b>206226</b>	<b>206225</b>	3374420 3374416	
19 20		5940344 TRCC 12 x 30	3,17 kg	70 mm Ø 13 mm	360 mm	110 mm	14 mm	3374417	<b>400837</b>	<b>400836</b>	3374416	
21 22		225950 TH 12 x 70	2,65 kg	Ø 12 mm	240 mm	130 mm	12 mm	3374461	<b>400767</b>	<b>400766</b>	3374460	
3 4	<b>MASHIO</b> (Terre moto)	5940344 TRCC 12 x 30	3,52 kg	70 mm Ø 12 mm	360 mm	110 mm	14 mm	F20120020	<b>206226</b>	<b>206225</b>	F201200219	
1 2	<b>OVLAC</b> (Versatil)	225950 TH 12 x 70	2,43 kg	60 mm Ø 12 mm	200 mm	100 mm	12 mm	-	<b>209372</b>	<b>209371</b>	-	
23 24	<b>POTTINGER</b>	TH 16X70	2,05 kg	-	245 mm	145 mm	12 mm	9762500230G	<b>412460</b>	<b>412459</b>	9762500240d	
25 26		228988 TFCC 12 x 40	2,56 kg	-	315 mm	100 mm	12 mm	966500210G	<b>412462</b>	<b>412461</b>	966500310D	

-  Cultivator points
-  Rejas de cultivador
-  Bicos de cultivadores
-  Lemiesze kultywatorów
-  Kultivatorschare

# AILERONS DE CULTIVATEURS



# AILERONS DE CULTIVATEURS

	Montage sur marques							OEM			OEM
	Type Para tipo Tipo Typ Passend zu										
1	<b>QUIVOGNE</b> (Universel) (Black bear)	5915250 TFCC 12 x 80	7,70 kg	45/75/ 12 mm	480 mm	100 mm	12 mm	-	<b>206227</b>		-
2		5915582 TFCC 14 x 90	7,70 kg	45/75/ 14 mm	480 mm	100 mm	12 mm	7002 622210	<b>206228</b>		-
3		1717263 TH 12 x 70	2,43 kg	60 mm Ø 12 mm	200 mm	100 mm	12 mm	-	<b>209372</b>	<b>209371</b>	-
4											
5	<b>RAZOL</b> (Aramix)	5915520 TFCC 12X40	2,20 kg	-	290 mm	100 mm	12 mm	003490	<b>412464</b>	<b>412463</b>	003489
6											
7	<b>RELIGIEUX</b>	-	3,17 kg	70 mm Ø 13 mm	360 mm	110 mm	14 mm	3374417	<b>400837</b>	<b>400836</b>	3374416
8											
9	<b>SOUCHU PINET</b>	-	3,52 kg	70 mm Ø 12 mm	360 mm	110 mm	14 mm	102228	<b>206226</b>	<b>206225</b>	102227
10											
11	<b>UNIVERSEL</b>	228994 TFCC 12X80	7 kg	-	480 mm	100 mm	12 mm	-	<b>400906</b>		-
12	<b>VÄDERSTAD</b>	228994 TFCC 12X80	2,04 kg	57 mm Ø 13 mm	200 mm	100 mm	12 mm	475.001	<b>400769</b>	<b>400768</b>	475.000
13											





# DES PIÈCES RENFORCÉES POUR LES TRAVAUX PROFONDS

REINFORCED PARTS FOR DEEP SOILS | PARTES REFORZADAS PARA TRABAJOS PROFUNDOS  
| PEÇAS REFORÇADAS PARA TRABALHOS EM PROFUNDIDADE | WZMOCNIONE CZĘŚCI DO  
GŁĘBOKIEJ PRACY | VERSTÄRKTE TEILE FÜR TIEFE UND HARTE ARBEIT

- **Des supports très haute résistance à la flexion et à l'usure**

*Flexion and wear high resistance  
Soportes muy resistentes a la flexión y el desgaste  
Resistência extremamente elevada à flexão e ao desgaste  
Wsporniki z bardzo wysoką odpornością na zginanie i zużycie  
Sehr hohe Biege- und Verschleißfestigkeit*

- **Des pièces conçues pour des travaux profonds**

*Parts designed for deep works  
Partes diseñadas para los trabajos profundos  
Peças desenvolvidas para trabalhos em profundidade  
Części przeznaczone do głębokiej pracy  
Teile für tiefe Arbeit entwickelt*

- **Des niveaux de rechargement élevés permettant la protection des zones les plus sollicitées**

*A high quality of hardfacing provides a strong protection of the most sensitive parts  
Recargos de calidad protejan los campos mas desgastados de las partes  
Níveis de recarga elevados que permitem a protecção das áreas mais solicitadas  
Wysoki poziom przeladowania pozwalający na ochronę najbardziej narażonych obszarów  
Hohe Qualität zum Schutz der am stärksten beanspruchten Bereiche*



# SOUS-SOLAGE





 SUBSOILING |  SUBSUELO |  SUBSOLO |  
 UPRAWA GŁĘBOSZOWA |  UNTERBODENLOCKERUNG



 **AGRI-POWER**





-  Subsoiler parts
-  Recambios de descompactador
-  Peças de descompactadores
-  Części głęboszy
-  Tiefenlockerteile

# PIÈCES DE DÉCOMPACTEURS



## PIÈCES DE DÉCOMPACTEURS

	Montage sur marques	Rechargement	Pièces								OEM			
	Type Para tipo Tipo Typ Passend zu	Hardfacing Recargo Recarga Przeladowywanie Hartmetall Ausweißen	Wearing parts Hartmetal Respuestos											
1	ACTISOL	✓	<b>Sabot sous-soleur</b> Shoe   Bota de subsolador   Bico   Stopa głębosza   Tiefenlockerermeißel	-	3,00 kg	10 mm	317 mm	400 mm	-	-	19100011	400696		
2		✓		-	3,50 kg	15 mm	360 mm	400 mm	-	-	19300011	400697		
3		✓		<b>Barre lame</b> Bar point   Barra lâmina   Barra da lâmina   Belka ostrza   Meißel	-	0,80 kg	10 mm	210 mm	60 mm	-	-	19100002	400692	
4		✓			-	2,04 kg	15 mm	235 mm	60 mm	-	-	19300003	400693	
5				<b>Pointe mobile carrée</b> Stick point   Punta mobile   Ponta móvel quadrada   Punkt ruchomy kwadratowy   Quadratische Wechselspitze	-	1,92 kg	-	420 mm	-	25 x 25 mm	-	19100004 19100005	400690	
6					-	1,60 kg	-	450 mm	-	22 x 22 mm	-	19100004 19100005	400691	
7			<b>HEAVY DUTY</b>	<b>Nez de protection</b> Carbide guards fits to Actisol   Karbidschutzvorrichtung für Actisol   Protezione de carburo para Actisol	-	3,10 kg	-	227 mm	60 mm	-	-	19300007	400805	
8	AGRISEM		<b>Bord d'attaque</b> Leading edge   Vorderkante   Borde de ataque	-	2,04 kg	-	-	-	-	70 mm Ø 12 mm	28132 28131	206233	206232	
9		✓		240236 TFHC 12X25	1,73 kg	24 mm	-	130 mm	-	70 mm Ø 13 mm	28132 28131	400915	400914	
10		<b>HEAVY DUTY</b>	<b>Soc - lame</b> Shore   Schare   Reja	-	16 kg	-	319 mm	504 mm	-	-	SOC654W-MC/ SOC653W-MC	412494	412493	
11		✓			-	10,70 kg	-	330 mm	450 mm	-	Ø 22 mm 2012-332 2012-331	400817	400816	
12	ALPEGO (Craker) (Super Craker)	✓	<b>Sabot sous-soleur</b> Shoe   Bota de subsolador   Bico   Stopa głębosza   Tiefenlockerermeißel	-	6,17 kg	-	70 mm	390 mm	-	28 mm Ø 13 mm	E06080	400774		
13		✓		-	6,70 kg	-	70 mm	335 mm	-	24 mm Ø 14 mm	E04625	400838		
14		✓			-	7,11 kg	18 mm	70 mm	432 mm	-	E56010	400860		
15	ASKEL		<b>Pointe</b> Point   Punta   Ponta   Punkt   Spitze	-	5,25	30	70	345	-	55 mm Ø 16 mm	-	400913		
16				5940265 TCO 12X50	1,4	20	70	160	-	50 mm Ø 12 mm	-	412477		
17		✓			5940265 TCO 12X51	1,45	20	70	160	-	-	412478		
18					245868 kit	6,61	-	-	-	-	80 mm Ø 16 mm	-	412480	
19		✓			245868 kit	6,65	-	-	-	-	-	412479		
20				<b>Barre lame</b> Bar point   Barra lâmina   Barra da lâmina   Belka ostrza   Meißel	245868 kit	5,99	65	40	600	-	-	412482	412481	
21					245868 kit	6,61	65	70/90	460	-	90 mm Ø 16 mm	-	412485	
22		✓			245868 kit	6,63	65	70/90	460	-	-	-	412486	
23				<b>Contre lame grand modèle</b> Landside (big)   Contra lâmina (alta)   Contra-lâmina grande   Duży przeciwstrze   Meißel (größer)	245868 kit	9,2	-	-	-	-	-	412488	412487	
24					245868 kit	6,1	-	-	-	-	80 mm Ø 16 mm	-	209228	209227
25	✓			245868 kit	6,13	-	-	-	-	-	400931	400930		
26	UNIVERSELLE	<b>HEAVY DUTY</b> ✓	<b>Semelle à souder</b>		4,5 kg	20	70	435	-	-	-	410394		

# PIÈCES DE DÉCOMPACTEURS

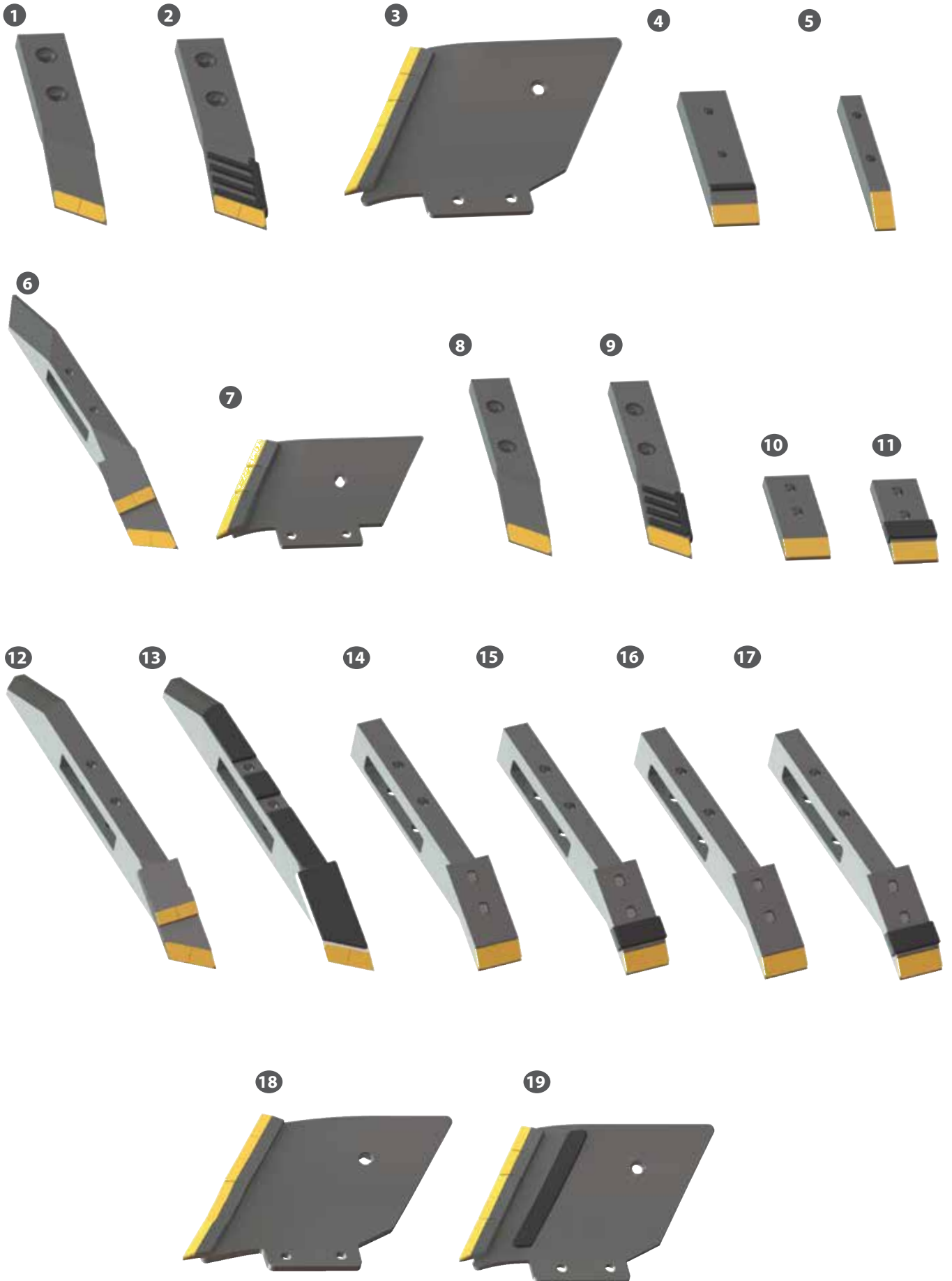



## PIÈCES DE DÉCOMPACTEURS



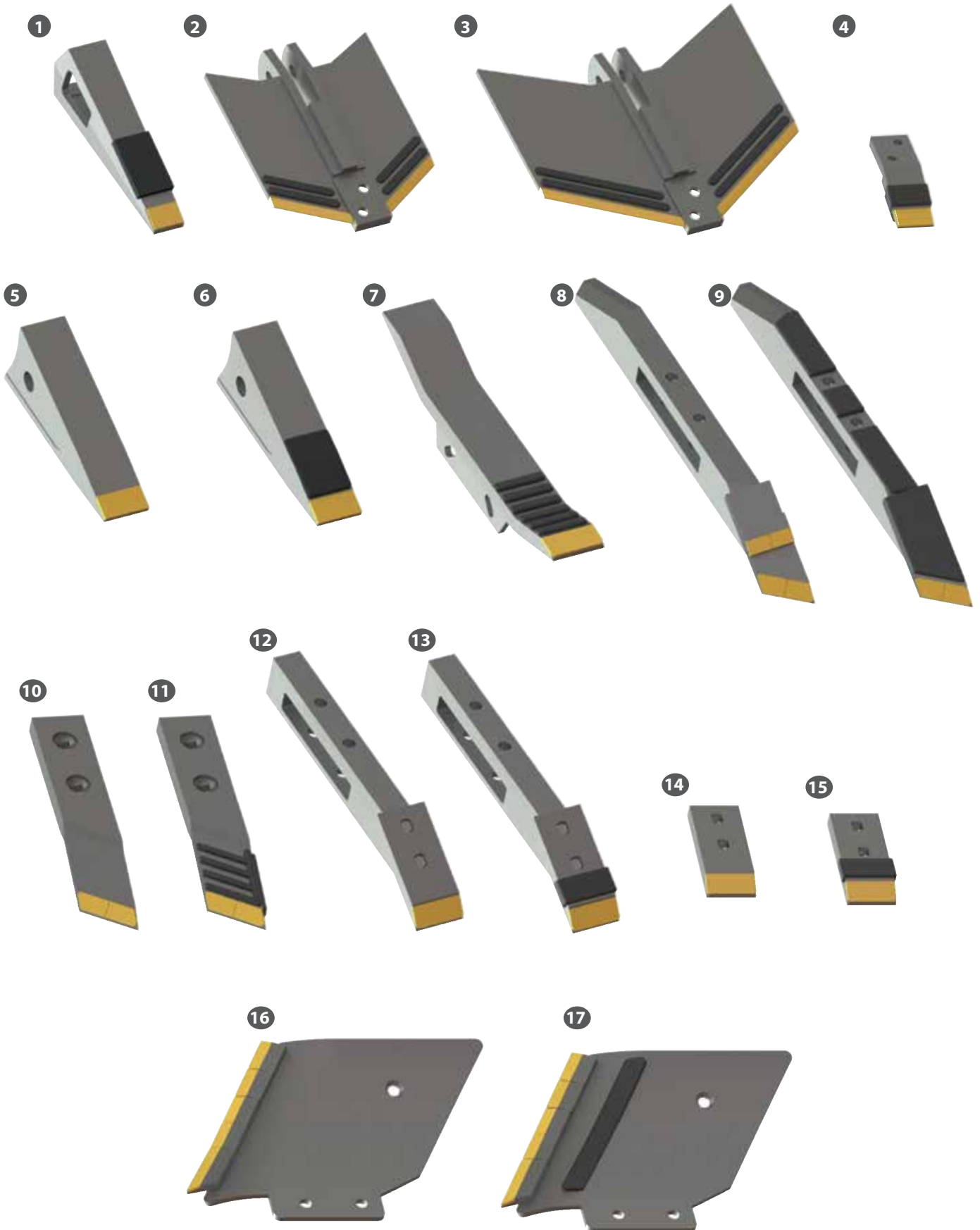

Montage sur marques	Rechargement	Pièces									OEM				
														Type Para tipo Tipo Typ Passend zu	Hardfacing Recargo Recarga Przeładowywanie Hartmetall Auschweißen
1	BONNEL	✓	Barre lame Bar point   Barra lâmina   Barra da lâmina   Belka ostrza   Meißel	5915310 TFCC 16 x 60	4,26 kg	25 mm	70 mm	340 mm	70 x 25 mm	80 mm Ø 16 mm	370.70.25/80	209178	209177		
2			Barre lame Bar point	5915310 TFCC 16 x 60	4,34 kg	25 mm	70 mm	340 mm	70 x 25 mm		209180	209179			
3			Contre lame grand modèle Landside (big)	245868 kit	6,03 kg	-	-	-	-		-	209228	209227		
2	CARRÉ		Barre lame Bar point	5915310 TFCC 16 x 60	4,34 kg	25 mm	70 mm	340 mm	70 x 25 mm	80 mm Ø 16 mm	-	209180	209179		
4	DURO/ JALLU	✓	Pointe Point   Punta   Ponta   Punkt   Spitze	229008 TCHC 14 x 45	3,65 kg	30 mm	70 mm	250 mm	70 x 30 mm	Ø 14 mm	-	209160			
5					1,70 kg	32 mm	32 mm	250 mm	32 x 32 mm		-	400782			
6	GARD	✓	Barre lame Bar point	-	6,27 kg	-	500 mm	-	-	85 mm Ø 14 mm	-	209226	209225		
7			Contre lame petit modèle Landside (small)	245868 kit	3,14 kg	-	-	-	-		-	209230	209229		
8			Barre lame Bar point   Barra lâmina   Barra da lâmina   Belka ostrza   Meißel	5965280 TFCC 14 x 50	3,50 kg	25 mm	60 mm	330 mm	60 x 25 mm		-	400787	400786		
9		✓	Barre lame Bar point   Barra lâmina   Barra da lâmina   Belka ostrza   Meißel	5915280 TFCC 14 x 50	3,57 kg	25 mm	60 mm	330 mm	60 x 25 mm	-	400789	400788			
10	GRÉGOIRE - BESSON	✓	Pointe Point   Punta   Ponta   Punkt   Spitze	5940265 TCO 12X50	1,40 kg	20 mm	70 mm	160 mm	70 x 20 mm	50 mm Ø 12 mm	-	412477			
11				5940265 TCO 12X51	1,45 kg	20 mm	70 mm	160 mm	70 x 20 mm		-	412478			
8				✓	Barre lame Bar point   Barra lâmina   Barra da lâmina   Belka ostrza   Meißel	5915280 TFCC 14X50	3,50 kg	25 mm	60 mm	330 mm	60 x 25 mm	85 mm Ø 14 mm	-	400787	400786
9				✓	Barre lame Bar point   Barra lâmina   Barra da lâmina   Belka ostrza   Meißel	5915280 TFCC 14X50	3,57 kg	25 mm	60 mm	330 mm	60 x 25 mm	-	400789	400788	
12					Contre lame grand modèle Landside (big)	245868 kit	9,12 kg	-	-	600 mm	-	-	206230	206229	
13				✓	Barre lame Bar point   Barra lâmina   Barra da lâmina   Belka ostrza   Meißel	245868 kit	9,30 kg	-	-	600 mm	-	80 mm Ø 16 mm	-	400846	400845
14					Barre lame Bar point   Barra lâmina   Barra da lâmina   Belka ostrza   Meißel	245868 kit	6,61 kg	-	-	-	-	-	-	412480	
15				✓	Contre lame grand modèle Landside (big)	245868 kit	6,65 kg	-	-	-	-	-	-	412479	
16					Contre lame grand modèle Landside (big)	245868 kit	6,61 kg	65 mm	70/90 mm	460 mm	-	-	-	412485	
17				✓	Contre lame grand modèle Landside (big)	245868 kit	6,63 kg	65 mm	70/90 mm	460 mm	-	90 mm Ø 16 mm	-	412486	
18					Contre lame grand modèle Landside (big)	245868 kit	9,20 kg	-	-	-	-	-	-	412487	412488
3					Contre lame grand modèle Landside (big)   Contra lamina (alta)   Contra-lâmina grande   Duży przeciwstrze   Meißel (gröÙ)	245868 kit	6,10 kg	-	-	-	-	80 mm Ø 16 mm	-	209228	209227
19		✓	Contre lame grand modèle Landside (big)	245868 kit	6,13 kg	-	-	-	-	-	-	400931	400930		
7			Contre lame petit modèle Landside (small)	245868 kit	3,14 kg	-	-	-	-	85 mm Ø 14 mm	-	209230	209229		

# PIÈCES DE DÉCOMPACTEURS



## PIÈCES DE DÉCOMPACTEURS

	Montage sur marques	Rechargement	Pièces													
	Type Para tipo Tipo Typ Passend zu	Hardfacing Recargo Przeladowywanie Hartmetall AuschweißBen	Wearing parts Hartmetal Respuestos													
1	<b>JEAN DE BRU - ZAZURCA</b>	✓	<b>Sabot sous-soleur</b> Shoe   Bota de subsolador   Bico   Stopa gębosza   Tiefenlockerermeißel	-	6,83 kg	112 mm	50 mm	325 mm	-	-	-	02/0171020	<b>412500</b>			
2	<b>KUHN</b>	✓	<b>Soc</b> Shore   Reja   Relha   Redflica   Schare	-	9,50 kg	12 mm	280 mm	-	-	-	-	K1800290	<b>400771</b>			
3		✓		-	13,50 kg	12 mm	450 mm	-	-	-	-	K1800130	<b>400772</b>			
4				<b>Pointe</b> Point   Punta   Ponta   Punkt   Spitze	-	1,75 kg	20 mm	60 mm	180 mm	-	-	520.476.00	<b>400773</b>			
5	<b>LELY</b> (Lelyroc)		<b>Sabot sous-soleur</b> Shoe   Bota de subsolador   Bico   Stopa gębosza   Tiefenlockerermeißel	-	4,63 kg	-	60 mm	258 mm	-	-	-	113	<b>219166</b>			
6		✓		-	4,73 kg	-	60 mm	258 mm	-	-	Ø 25 mm		<b>400813</b>			
7	<b>MASHIO</b>	✓	<b>Sabot sous-soleur</b> Shoe   Bota de subsolador   Bico   Stopa gębosza   Tiefenlockerermeißel	-	5,70 kg	-	70 mm	435 mm	-	28 mm Ø 13 mm	R17820661	<b>400770</b>				
8	<b>MICHEL</b> (EA 80 mm)		<b>Barre lame</b> Bar point   Barra lâmina   Barra da lâmina   Belka ostrza   Meißel	not included	9,12 kg	-	600 mm	-	-	-	-	-	206230	206229		
9		✓		-	9,30 kg	-	600 mm	-	-	-	-	-	400846	400845		
10					5915310 TFCC 16 x 60	4,26 kg	-	70 mm	340 mm	-	-	80 mm Ø 16 mm	-	209178	209177	
11		✓			5915310 TFCC 16 x 60	4,34 kg	-	70 mm	340 mm	-	-	80 mm Ø 16 mm	-	209180	209179	
12					245868 kit	6,61 kg	-	-	-	-	-	-	-	<b>412480</b>		
13		✓			245868 kit	6,65 kg	-	-	-	-	-	-	-	<b>412479</b>		
14					5940265 TCO 12X50	1,40 kg	20 mm	70 mm	160 mm	-	-	-	-	<b>412477</b>		
15	✓		5940265 TCO 12X51	1,45 kg	20 mm	70 mm	160 mm	-	-	50 mm	-	<b>412478</b>				
16			<b>Contre lame grand modèle</b> Landside (big)   Contra lâmina (alta)   Contra-lâmina grande	245868 Kit	6,03 kg	-	-	-	70 x 20	80 mm Ø 16 mm	-	209228	209227			
17	✓		Duży przeciwstrze   Meißel (größ)	-	6,13 kg	-	-	-	70 x 20	80 mm Ø 16 mm	-	400931	400930			

-  Subsoiler parts
-  Recambios de descompactador
-  Peças de descompactadores
-  Części głęboszy
-  Tiefenlockerteile

# PIÈCES DE DÉCOMPACTEURS

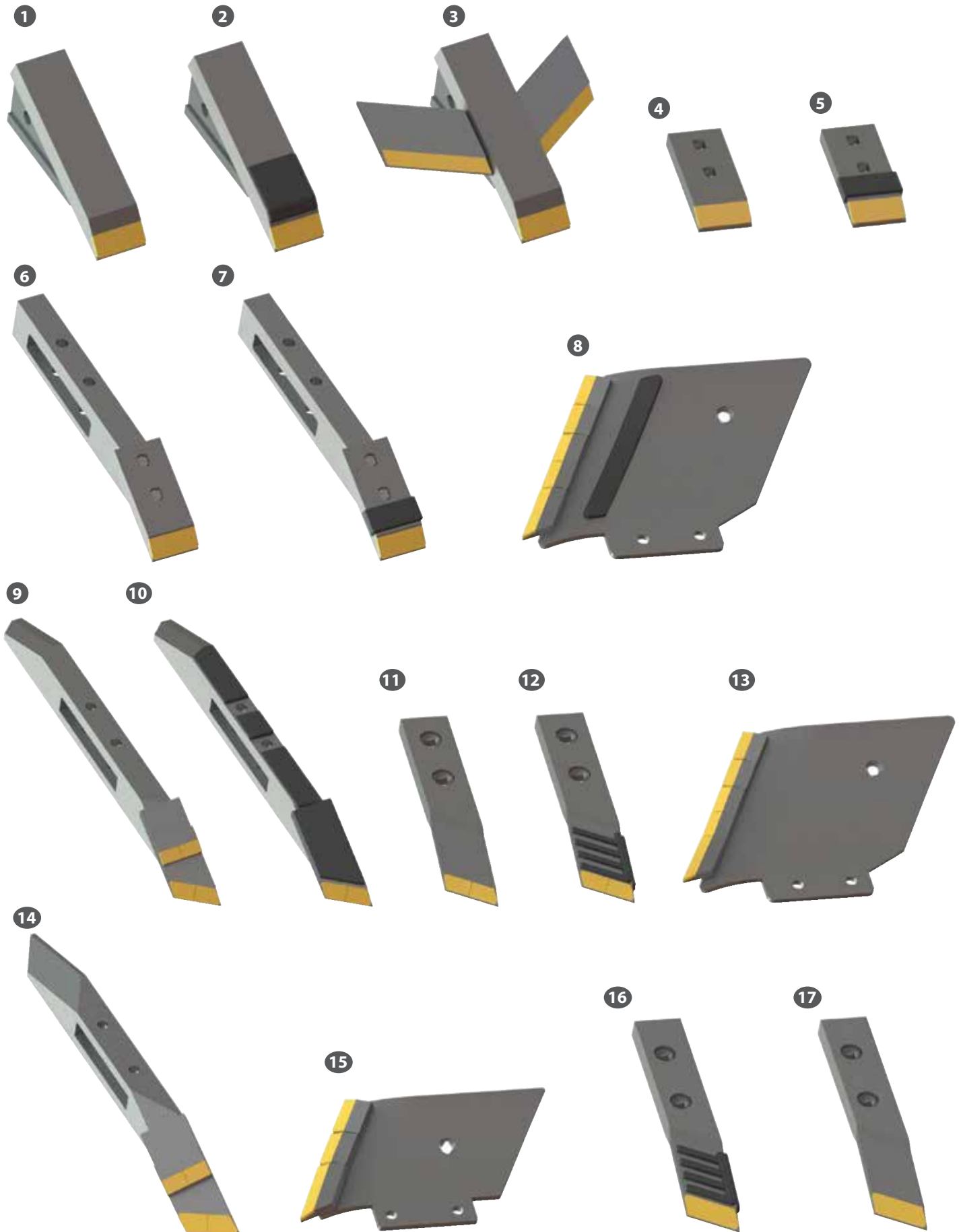

## PIÈCES DE DÉCOMPACTEURS

	Montage sur marques	Rechargement	Pièces								OEM			
	Type Para tipo Tipo Typ Passend zu	Hardfacing Recarga Recarga Przeladowywanie Hartmetall Auschweißen	Wearing parts Hartmetall Respuestos											
1	QUIVOGNE		<b>Sabot sous-soleur</b> Shoe   Bota de subsollador   Bico   Stopa głębosza   Tiefenlockermeißel	-	6,24 kg	-	70 mm	270 mm	-		0022	206231		
2				-	6,34 kg	-	70 mm	270 mm	-	Ø 18 mm	0022	400812		
3					-	8,26 kg	-	-	-	-	0022	209189		
4				<b>Pointe</b> Point   Punta   Ponta   Punkt   Spitze	5940265 TCO 12X50	1,40 kg	20 mm	70 mm	160 mm	-	50 mm Ø 12 mm	-	412477	
5		✓			5940265 TCO 12X51	1,45 kg	20 mm	70 mm	160 mm	-	50 mm Ø 12 mm	-	412478	
6				<b>Barre lame</b> Bar point   Barra lâmina   Barra da lâmina   Belka ostrza   Meißel	245868 kit	6,61 kg	-	-	-	-		-	412480	
7		✓			245868 kit	6,65 kg	-	-	-	-		-	412479	
8		✓		<b>Contre lame grand modèle</b> Landside (big)   Contra lâmi- na (alta)   Contra-lâmina grande   Duży przeciwstrze   Meißel (groß)	245868 kit	6,13 kg	-	-	-	-	80 mm Ø 16 mm	-	400931	400930
9	RABE			not included	9,12 kg	-	600 mm	-	-		-	206230	206229	
10		✓			-	9,30 kg	-	600 mm	-	-	-	400846	400845	
11				<b>Barre lame</b> Bar point   Barra lâmina   Barra da lâmina   Belka ostrza   Meißel	5915310 TFCC 16 x 60	4,26 kg	25 mm	70 mm	340 mm	70 x 25 mm	80 mm Ø 16 mm	-	209178	209177
12		✓			5915310 TFCC 16 x 60	4,34 kg	25 mm	70 mm	340 mm	70 x 25 mm		-	209179	209180
13				<b>Contre lame grand modèle</b> Landside (big)   Contra lâmi- na (alta)   Contra-lâmina grande   Duży przeciwstrze   Meißel (groß)	245868 Kit	6,03 kg	-	-	-	-		-	209228	209227
14	RAZOL (EA 85 mm)		<b>Barre lame</b> Bar point   Barra lâmina   Barra da lâmina   Belka ostrza   Meißel	-	6,27 kg	-	500 mm	-	-		-	209226	209225	
15			<b>Contre lame petit modèle</b> Landside (small)   Contra lâmina (pequena)   Meißel (klein)	245868 Kit	3,14 kg	-	-	-	-		-	209230	209229	
16			<b>Barre lame</b> Bar point   Barra lâmina   Barra da lâmina   Belka ostrza   Meißel	5915280 TFCC 14 x 50	3,50 kg	25 mm	60 mm	330 mm	60 x 25 mm	85 mm Ø 14 mm	-	400787	400786	
17		✓			5915280 TFCC 14 x 50	3,57 kg	25 mm	60 mm	330 mm	60 x 25 mm		-	400789	400788
17	TECHMAGRI	✓	<b>Barre lame</b> Bar point   Barra lâmina   Barra da lâmina   Belka ostrza   Meißel	5915280 TFCC 14 x 50	3,57 kg	-	60 mm	330 mm	-	85 mm Ø 14 mm	-	400789	400788	



# UNE GAMME ESSENTIELLE POUR LES VITICULTEURS

AN ESSENTIAL RANGE FOR WINEGROWERS |

GAMA ESENCIAL PARA LOS VITICULTORES | UMA GAMA ESSENCIAL PARA OS VITICULTORES |

NIEZBĘDNY ASORTYMENT DLA PLANTATORÓW WINOROŚLI | ESSENZIELLE PALETTE FÜR WINZER

## ● Sélection des pièces courantes

*Common parts selection  
Selección de partes corrientes  
Seleção de peças padrão  
Wybór standardowych części  
Gängigen Teile Auswahl*

## ● Précision des travaux

*Works accuracy  
Precisión de los trabajos  
Precisão do trabalho  
Dokładność pracy  
Arbeiten Präzision*

## ● Cahier des charges optimal pour un parfait compromis "résistance chocs et usure"

*Optimal specification  
Especificaciones óptimas  
Especificações ótimas para um compromisso perfeito entre "resistência ao impacto e desgaste"  
Optymalne specyfikacje dla idealnego kompromisu między „odpornością na wstrząsy i zużyciem”  
Optimal Pflichtenheft*



# VIGNE

 "VINEYARD" WEARING PARTS |  REPUESTOS DE CARBURA PARA "LA VINA"  
|  PEÇAS DE DESGASTE « VINHA » |  CZĘŚCI ZUŻYWAJĄCE SIĘ « WINOROŚL » |  
 VERSCHLEISSTEILE FÜR "REBE"



 **AGRI-POWER**



« Vineyard » wearing parts  
Repuestos de carbura para « la vina »  
Peças de desgaste « Vinha »  
Części zużywające się « Winorośl »  
Verschleissteile für « Rebe »

# PIÈCES D'USURE "VIGNE"

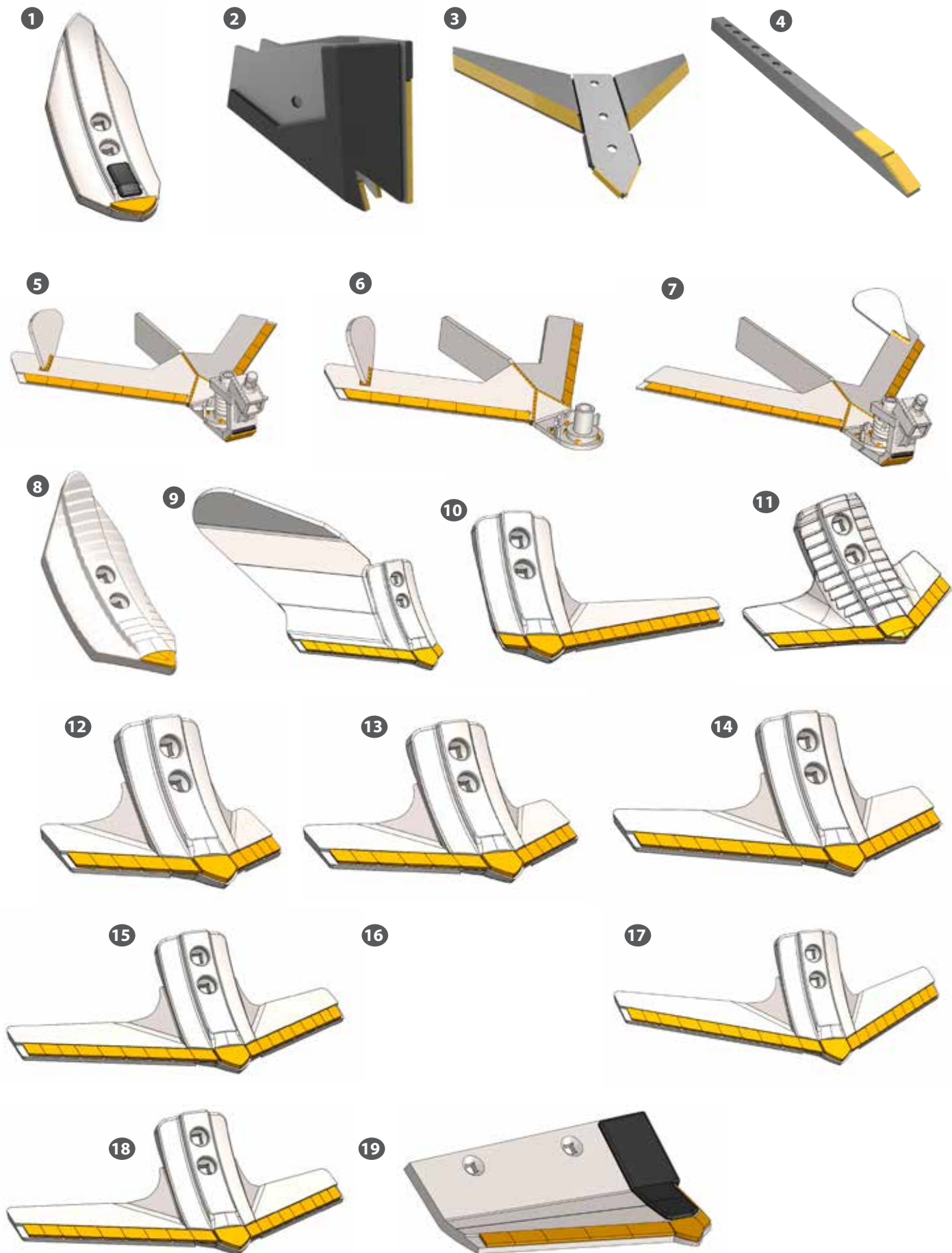



## PIÈCES D'USURE "VIGNE"

	Montage sur marques	Rechargement	Pièces													
	Type Para tipo Tipo Typ Passend zu	Hardfacing Recarga Recarga Przeladowywanie Hartmetall Auschweißen	Wearing parts Hartmetall Respuestos													⬡
1	UNIVERSEL		Cote de melon		2,2 kg	35 mm	88 mm	250 mm	-	35 mm Ø 11 mm					441959	
2	ACTISOL	<b>HEAVY DUTY</b>	Nez de protection		3,1 kg	-	227 mm	60 mm	-	-	19300007				400805	
3			Sabot sous-soleur		3 kg	10 mm	330 mm		-	-	19100011				400696	
3					3,5 kg	15 mm	500 mm		-	-	19300011				400697	
4			Pointe Mobile		1,6 kg	-		450 mm	22 mm	-	19100004 19100005				400691	
5			Intersep à ressort type V47		9,1 kg	-	490 mm	155 mm	-	-			442118	442117		
6			Intersep type V47		4,9 kg	-	490 mm	102 mm	-	-			442120	442119		
7			Intersep à ressort type V60		10,2 kg	-	563 mm	155 mm	-	-			442113	442114		
8			<b>HEAVY DUTY</b>	Cote de melon		-	-	250 mm	-	35 mm Ø 11 mm						447013
9			<b>HEAVY DUTY</b>	Soc Butteur		4,4 kg	-	315 mm	217 mm	-	35 mm Ø 11 mm			441962	441961	
10		<b>HEAVY DUTY</b>	Rasette à plantes		2,6 kg	-	294 mm	131 mm	-	35 mm Ø 11 mm			442016	442017		
11		<b>HEAVY DUTY</b>	Soc triangle		-	-	-	-	-	35 mm Ø 11 mm					446993	
12		<b>HEAVY DUTY</b>			2,26 kg	-	204 mm	131 mm	-	-						442007
13		<b>HEAVY DUTY</b>			2,56 kg	-	254 mm	131 mm	-	35 mm Ø 11 mm						442008
14		<b>HEAVY DUTY</b>			2,87 kg	-	308 mm	131 mm	-	-						442009
15	BOISSELET	<b>HEAVY DUTY</b>			3,2 kg	-	357 mm	131 mm	-	-						442010
16		<b>HEAVY DUTY</b>		Soc triangle branches inégales		-	-	360 mm	-	-				448531	448532	
17		<b>HEAVY DUTY</b>		Soc triangle		3,4 kg	-	405 mm	131 mm	-	35 mm Ø 11 mm					441967
18		<b>HEAVY DUTY</b>		Soc décavillonneur		4,9 kg	-	357 mm	62 mm	-	-			442049	442048	
19		<b>HEAVY DUTY</b>		Soc décavillonneur "Bourgogne"		4,5 kg	-	281 mm	62 mm	-	-			442051	442050	

- « Vineyard » wearing parts
- Repuestos de carbura para « la vina »
- Peças de desgaste « Vinha »
- Części zużywające się « Winorośl »
- Verschleissteile für « Rebe »

## PIÈCES D'USURE "VIGNE"





# PIÈCES D'USURE "VIGNE"

	Montage sur marques	Rechargement	Pièces							OEM			
	Type Para tipo Tipo Typ Passend zu	Hardfacing Recarga Recarga Przeładowywanie Hartmetall Auschweißen	Wearing parts Hartmetal Respuestos										
1	BOISSELET	✓	Lame type CUTMATIC	1,9 kg	8 mm	370 mm	38 mm	-	-	-	442086	442085	
2		✓		2,1 kg	8 mm	417 mm	38 mm	-	-	-	442088	442087	
3		✓		-	-	512 mm	-	-	-	-	-	446830	
4				Lame sabre type CUTMATIC	2,4 kg	8 mm	350 mm	38 mm	-	-	-	448091	448092
4					2,6 kg	8 mm	400 mm	38 mm	-	-	-	448093	448093
4		✓		Disque type PETALMATIC	2,1 kg	7 mm	250 mm	20,5 mm	-	-	-	442079	442080
5		✓			4,1 kg	7 mm	350 mm	-	-	-	-	442074	442075
6				Disque émotteur	5,2 kg	-	373 mm	36 mm	25,5 mm	-	-	448089	448090
7		BRAUN	✓	Lame intersep	6 kg	8 mm	430 mm	55 mm	-	190 mm Ø 12 mm	-	442098	442099
8	CLEMENS		Lame intersep type RADIUS	-	-	370 mm	-	-	-	-	448995	448996	
9				-	-	500 mm	-	-	-	-	448997	448998	



# UNE SÉLECTION DE COMPOSANTS POUR CONSTRUIRE OU RÉNOVER VOS PIÈCES CARBURE

- **Composants équipés de plaquettes de carbure très haute résistance**

*Components made by high resistance carbide plates*

*Componentes con placas de carburo alta resistencia*

*Componentes equipados com pastilhas de carboneto de alta resistência*

*Komponenty wyposażone we wkładki z węglików spiekanych o wysokiej wytrzymałości*

*Bauteile mit hochfesten Hartmetalleinsätzen*

- **À assembler à basse température au poste à souder traditionnel**

*Assemble the trips with a traditional welding machine at low temperature*

*Ensamblar a temperatura mínima con un puesto de soldadura tradicional*

*Montagem a baixa temperatura com uma unidade de soldadura tradicional*

*Do montażu w niskiej temperaturze przy użyciu tradycyjnego urządzenia spawalniczego*

*In der traditionellen Schweißmaschine bei niedriger Temperatur montiert*

- **Une gamme complète pour une protection plus précise**

*A complete range for a more specific protection*

*Una gama completa para una protección más precisa*

*Uma gama completa para uma proteção mais precisa*

*Kompletny asortyment zapewniający bardziej precyzyjną ochronę*

*Ein komplettes Sortiment für präziseren Schutz*







# MISES À SOUDER

 FLAT WELD-ON STRIPS |  PIEZAS PARA SOLDAR PLANAS  
|  PEÇAS PARA SOLDAR |  ELEMENTY DO WSPAWANIA |  
 FLACH ANSWEISSTEILEN



 **AGRI-POWER**

-  Weld-on stubble ploughing points
-  Puntas de cultivador para soldar
-  Pontas para soldar
-  Końcówki spawane
-  Einschweisspitzen für mulchgrubber



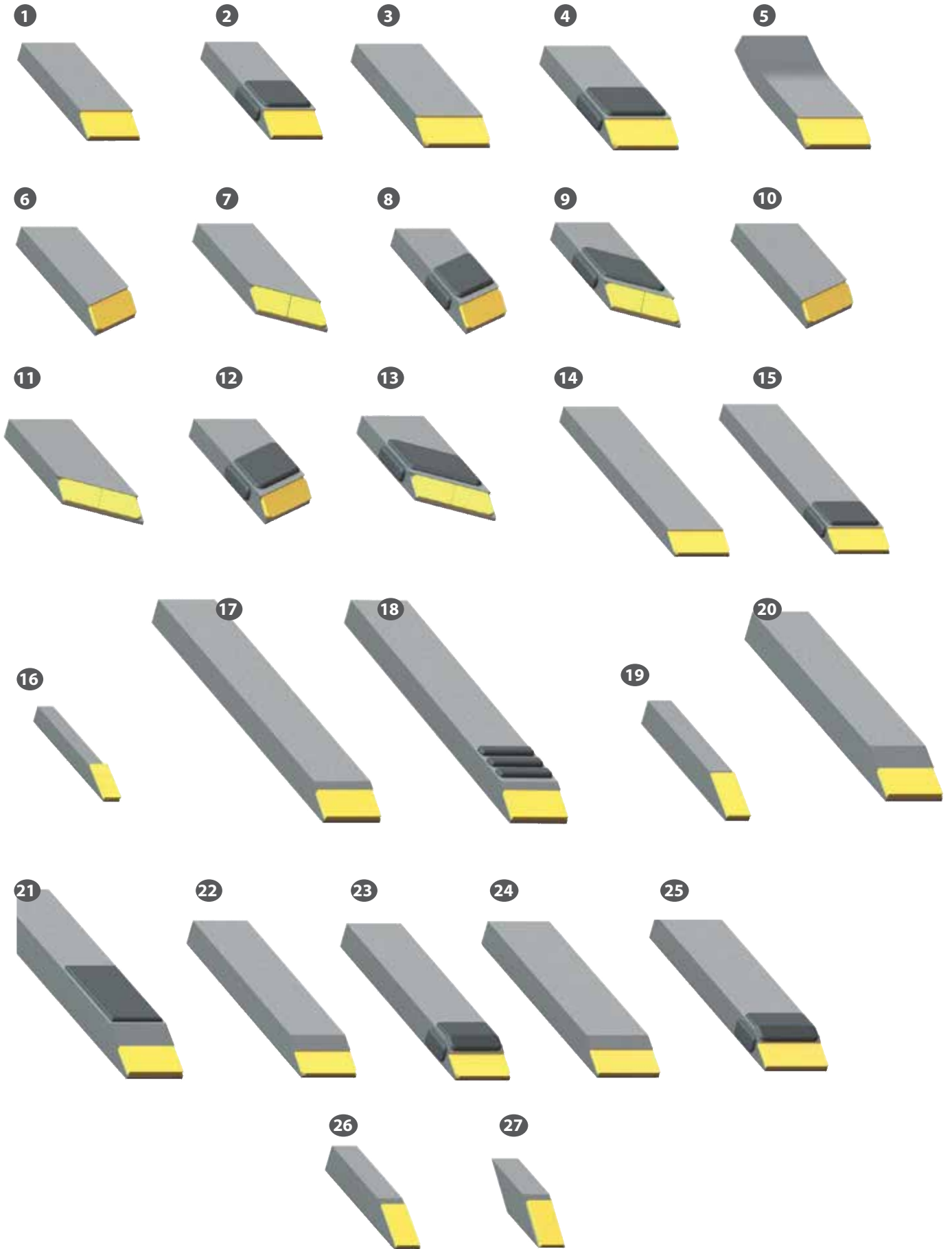

# POINTE À SOUDER





# POINTES À SOUDER

	Montage sur marques	Rechargement							
	Type Para tipo Tipo Typ Passend zu	Hardfacing Recargo Recarga Przeladowywanie Hartmetall Auschweißen							
1	<b>POINTE À SOUDER</b> <i>Weld-on stubble ploughing points</i> <i>Puntas de cultivador para soldar</i> <i>Pontas para soldar</i> <i>Końcówki spawane</i> <i>Einschweispitzen für</i> <i>Mulchgrubber</i>		1,44 kg	20 mm	60 mm	160 mm	209480		
2		✓	1,51 kg		60 mm	160 mm	400660		
3			1,72 kg		70 mm	160 mm	217963		
4		✓	1,79 kg		70 mm	160 mm	400659		
5			1,72 kg		70 mm	160 mm	209224		
6			1,39 kg		20 mm	60 mm	170 mm	206224	206223
7			1,46 kg			60 mm	170 mm	400665	400664
8		✓	1,46 kg		22 mm	60 mm	170 mm	400665	400664
9			1,59 kg			70 mm	170 mm	209162	209161
10			1,59 kg		25 mm	70 mm	170 mm	209162	209161
11			1,66 kg			70 mm	170 mm	400667	400666
12		✓	1,66 kg		30 mm	70 mm	170 mm	400667	400666
13			3,23 kg			70 mm	300 mm	209166	
14			3,23 kg		30 mm	70 mm	300 mm	209166	
15		✓	4,60 kg	70 mm		300 mm	400661		
16			0,61 kg	22 mm	35 mm	80 mm	400802		
17			4,12 kg	25 mm	60 mm	370 mm	400877		
18		✓	4,14 kg		60 mm	370 mm	400878		
19			0,80 kg	30 mm	35 mm	80 mm	209165		
20			3,89 kg		60 mm	300 mm	412517		
21		✓	3,91 kg	30 mm	60 mm	300 mm	412518		
22			4,60 kg		70 mm	300 mm	219164		
23		✓	4,67 kg	30 mm	70 mm	300 mm	400662		
24			5,33 kg		80 mm	300 mm	209163		
25		✓	5,40 kg	32 mm	80 mm	300 mm	400663		
26			1,26 kg		35 mm	80 mm	209223		
27			0,80 kg	35 mm	35 mm	80 mm	209164		

-  Flat weld-on strips
-  Piezas planas para soldar
-  Peças planas para soldar
-  Elementy do wstawiania "płaskie"
-  Flach answeissteilen

# MISES À SOUDER "PLATES"



1



2

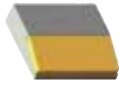

3

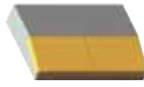

4



5



6



7



8



9



10



11



12



13



14

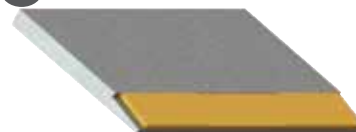

15



16



17



18



19



20





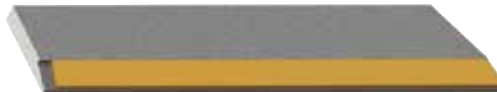

21









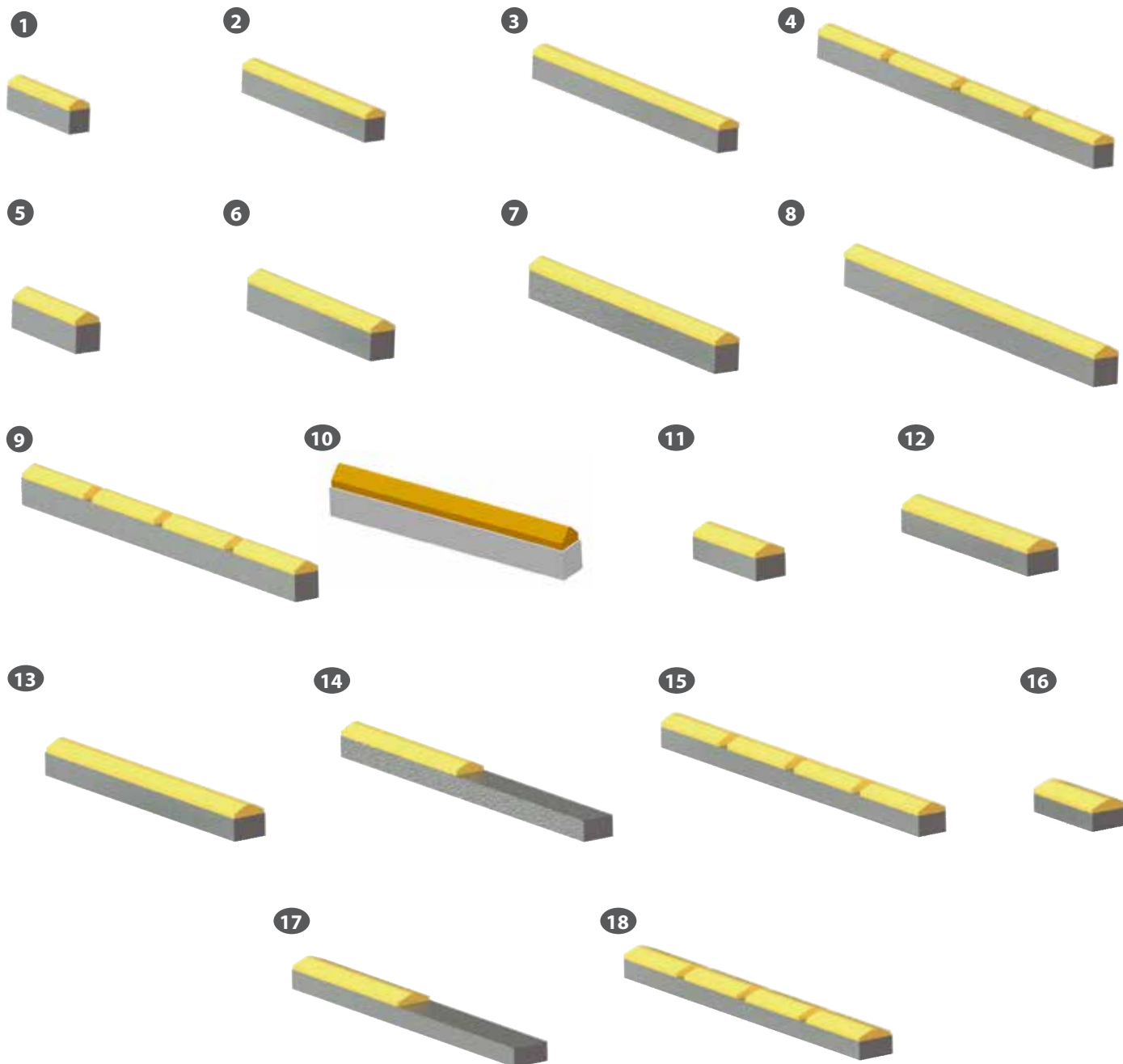

# MISES À SOUDER "PLATES"

Montage sur marques							
Type	Para tipo						
	Typo						
	Typ						
	Passend zu						
1	<b>RECTANGULAIRES</b>  <i>Rectangular Rectangular Retangulares Prostokątne Rechteckig</i>	0,11 kg	12 mm	30 mm	40 mm	400503	
2		0,16 kg		45 mm	40 mm	219167	
3		0,22 kg		60 mm	40 mm	219168	
4		0,27 kg		70 mm	40 mm	219169	
5		0,32 kg		90 mm	40 mm	219170	
6		0,55 kg		135 mm	40 mm	219171	
7		0,64 kg		180 mm	40 mm	219172	
8		0,80 kg		225 mm	40 mm	219173	
5		0,72 kg	14 mm	70 mm	90 mm	413545	
9	<b>BISEAUTÉES</b>  <i>Beveled Biselada Biseladas Skošne Abgeschrägt</i>	0,30 kg	12 mm	90 mm	40 mm	209168	209167
10		0,45 kg		135 mm	40 mm	209170	209169
11		0,60 kg		180 mm	40 mm	209172	209171
12		0,65 kg		225 mm	40 mm	400700	400699
13		0,80 kg		270 mm	40 mm	400702	400701
14		1,01 kg		120 mm	80 mm	209188	209187
15		0,51 kg		135 mm	40 mm	206235	206234
16		2,31 kg		320 mm	70 mm	209173	209174
17		3,00 kg		450 mm	70 mm	400704	400703
18		3,30 kg		500 mm	70 mm	400706	400705
19		3,60 kg		550 mm	70 mm	400708	400707
20		1,18 kg		70 mm	180 mm	400885	400884
21		2,60 kg		70 mm	360 mm	400887	400886
		1,50 kg	15 mm	40 mm	340 mm	412520	412519
	<b>BISEAUTÉES RECHARGÉES</b> <i>Reloaded bevels Biseladas recarregada Przeładowywane skošne</i>		12 mm	80 mm	120 mm	400605	400604

-  *Weld-on strips for power harrow tines*
-  *Piezas para soldar dientes de grada*
-  *Suporte de soldadura para dentes de grade*
-  *Gniazda do spawania zębów brony*
-  *Anschweißteile für Kreiseleggenzinken*

## MISES À SOUDER POUR DENTS DE HERSE







-  *Weld-on strips for landsides*
-  *Angulares para solda*
-  *Ângulos de soldadura*
-  *Kątowniki spawalnicze*
-  *Anschwei teilen für Anlagen*

## CORNIÈRES À SOUDER













# MISES À SOUDER POUR DENTS DE HERSE

	Montage sur marques						Ref
	Type Para tipo Tipo Typ Passend zu						
1	<b>MISES À SOUDER POUR DENTS DE HERSES</b> <i>Weld-on strips for power harrow tines</i> <i>Piezas para soldar dientes de grada</i> <i>Suporte de soldadura para dentes de grade</i> <i>Gniazda do spawania zębów brony</i> <i>Anschweißteile für Kreiseleggenzinken</i>		0,06 kg	10 mm	45 mm	14 mm	400911
2			0,11 kg		90 mm		207161
3			0,17 kg		135 mm		400863
4			0,25 kg		200 mm		209157
5			0,055 kg	12 mm	45 mm	17 mm	411919
6			0,16 kg		90 mm		400864
7			0,24 kg		135 mm		400865
8			0,32 kg		180 mm		400866
9			0,35 kg	200 mm	400862		
10			0,07 kg	13 mm	71 mm	8 mm	400917
11			0,09 kg	15 mm	45 mm	15 mm	400912
12			0,18 kg		90 mm		207162
13			0,27 kg		135 mm		400698
14			0,32 kg		190 mm		209389
15			0,40 kg	200 mm	209156		
16			0,11 kg	19 mm	45 mm	15 mm	207209
17			0,39 kg		190 mm		209390
18			0,51 kg		200 mm		209155

# CORNIÈRES À SOUDER



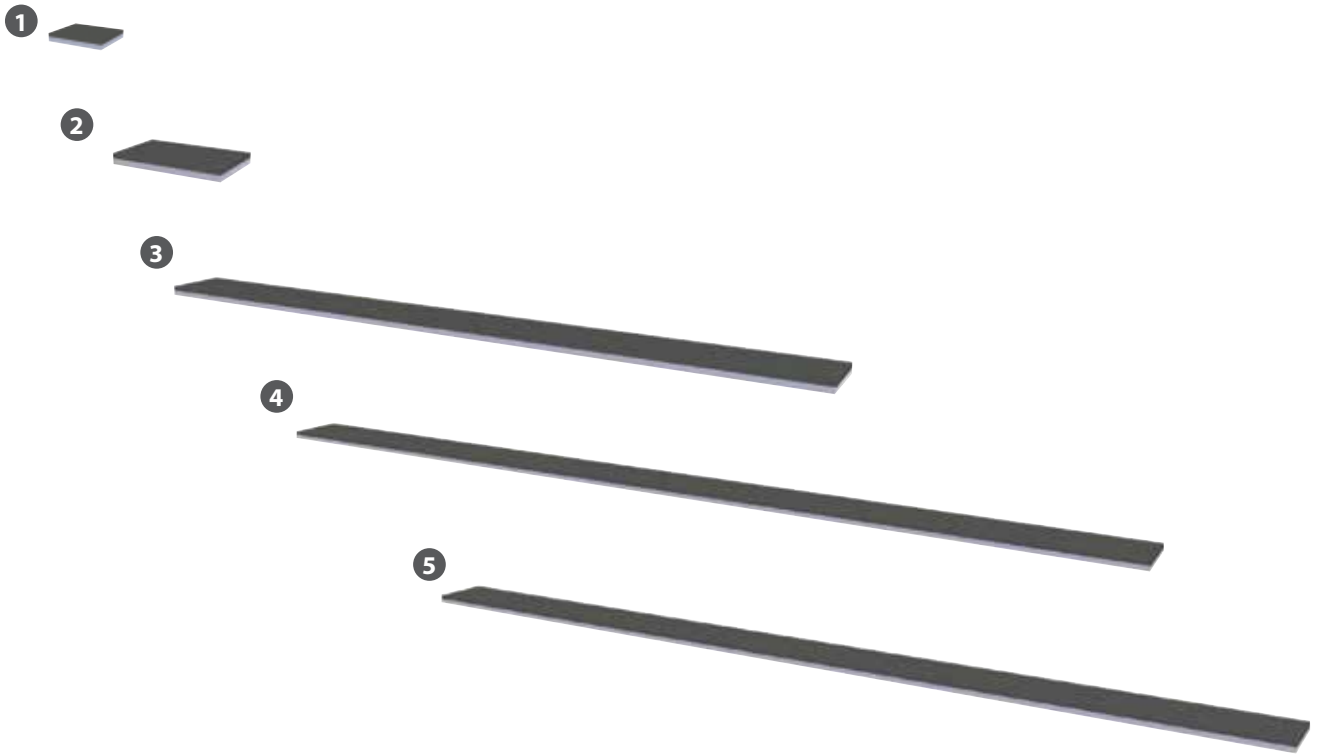

	Montage sur marques		Rechargement						Ref
	Type Para tipo Tipo Typ Passend zu		Hardfacing Recarga Recarga Przeładowywanie Hartmetall Auschweißen						
1	<b>CORNIÈRES À SOUDER</b> <i>Weld-on strips for landsides</i> <i>Angulares para solda</i> <i>Ángulos de soldadura</i> <i>Kątowniki spawalnicze</i> <i>Anschwei teilen für Anlagen</i>		✓	0,30 kg	20 mm	80 mm	50 mm	209159	
2			✓	0,50 kg	20 mm	130 mm	50 mm	209158	

-  Hardfacing bars
-  Barras de recarga
-  Barras de recarga
-  Belki wzmacniające
-  Verschleißplatte

# BARRES DE RECHARGEMENT



# BARRES DE RECHARGEMENT

	Montage sur marques	Rechargement					Ref
	Type Para tipo Tipo Typ Passend zu	Hardfacing Recargo Recarga Przeladowywanie Hartmetall AuschweiBen					
1		✓	0,40 kg	12 mm	70 mm	60 mm	209275
2	<b>BARRES DE RECHARGEMENT</b>	✓	0,60 kg	12 mm	100 mm	60 mm	209276
3	Hardfacing bars	✓	4,00 kg	12 mm	700 mm	60 mm	209277
4	Barras de recargo	✓	6,85 kg	12 mm	1200 mm	60 mm	209278
5	Barras de recarga	✓	8,00 kg	12 mm	1200 mm	70 mm	209279
	Belki wzmacniające						
	Verschleißplatte						





# PENSEZ À REMPLACER LA BOULONNERIE !

REMEMBER TO CHANGE THE NUTS AND BOLTS ! |

PIENSA A SUSTITUIR LA TORNILLERIA ! | NÃO ESQUECEM DE SUBSTITUIR AS PORCAS E OS PARAFUSOS! |

PAMIĘTAJ O WYMIANIE NAKRĘTEK I ŚRUB ! | ERWÄGEN, DIE SCHRAUBEN UND MUTTERN ZU WECHSELN !

- **Une gamme de fixations adéquates pour toutes les pièces carbure**

*A full range of fixations fitting with all carbide parts*

*Una gama completa de fijaciones compatibles con todas las partes de carburo*

*Uma gama de elementos de fixação para todas as peças em carboneto*

*Gama odpowiednich elementów złącznych do wszystkich części z węglików spiekanych*

*Ein komplettes Fixieren Sortiment mit Hartmetall vereinbar ist*

- **Remplacer la boulonnerie évite de détériorer le support et supprime les vibrations dans la pièce carbure**

*Replace your bolts and nuts to prevent from support degradation*

*Sustituir la tornilleria evita el desgaste de la parte de carburo*

*A substituição dos parafusos evita danificar o suporte e elimina as vibrações na peça de carboneto*

*Wymiana śrub pozwala uniknąć uszkodzenia wspornika i eliminuje wibracje części z węglików spiekanych.*

*Schrauben austauschen, um Schäden an der Halterung zu vermeiden*







# BOULONNERIE

 NUTS AND BOLTS |  TORNILLERÍA |  PARAFUSOS E PORCAS |  ŚRUBY |  
 SCHRAUBEN UND MUTTERN





 **AGRI-POWER**

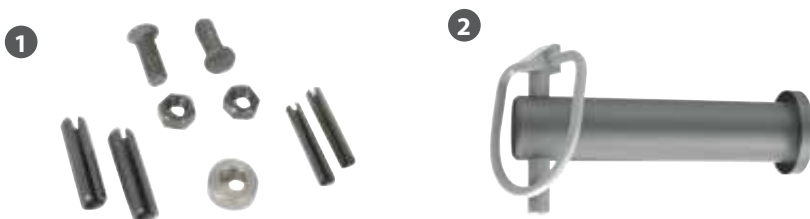

-  Nuts and bolts
-  Tornilleria
-  Parafusos e porcas
-  Šruby
-  Schrauben und muttern

# BOULONNERIE



Montage sur marques		REF. 
Type Para tipo Tipo Typ Passend zu		
1	<b>Kit fixation avec bague lame Type Michel</b> Fixation kit with ring, « Michel » type blade   Kit de fijación, hoja tipo « Michel »   Zestaw mocujący z pierścieniem typu Michel   Kit de fixação com anel tipo Michel   Befestigungsset, Klinge vom Typ « Michel »	245868
2	<b>Axe avec goupille type Amazone</b> Pin   Eje con pasador   Eixo com pino   Kolek z zawleczką   Achse mit Splint	5160114

## PONT DE LAME

**KUH52596600**

Affectation : HR103 | HR1003D  
 | HR4003 | HR4503 | HR5003 |  
 HR6003DR

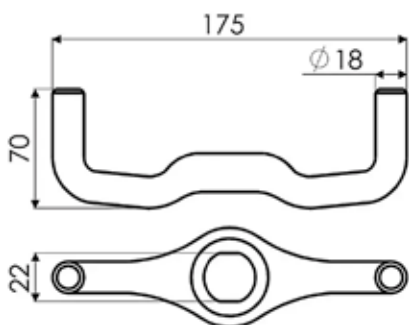

## GOUPILLE AUTOMATIQUE POUR DENTS MONTAGE RAPIDE

**KUH50086310**

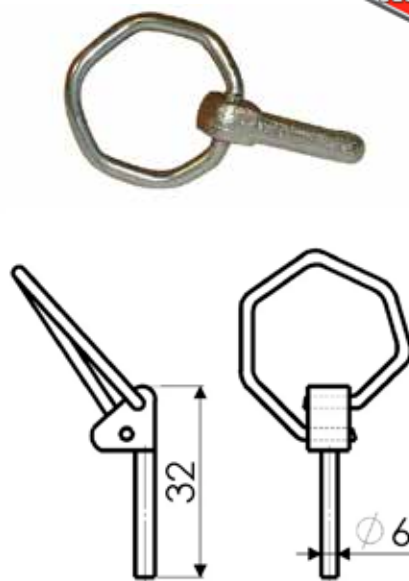



Cone-head bolt  
Cabeza cónica  
Parafuso de cabeça cônica  
Śruby z łbem stożkowym  
Kegelschrauben



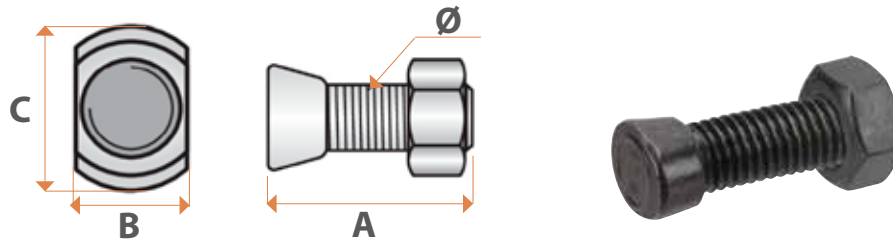

## BOULONS TÊTE CONIQUE



Ref	Ø	A	Cx B	Classe	OEM	📦
				Standing Clase Klasa Klasse Klasse		
<b>KVE013228R</b> 	12	34	16x13,5	12.9	013228R 013224 9941225	40 📦
<b>5940320</b>	12	34	16x13,5	12.9	013228R 013224 9941225	25 📦
<b>3705800</b>	12	34	16x13,5	12.9	013228R 013224 9941225	10 🌐
<b>251961</b>	12	35	-	8.8	-	25 📦
<b>226684</b>	12	36	-	-	H0609470	25 📦
<b>223172</b> 	12	38	-	-	KK013234R	50 📦
<b>5940324</b>	12	38	16x13,5	12.9	KK013234R	25 📦
<b>3705804</b>	12	38	16x13,5	12.9	KK013234R	10 🌐
<b>5940322</b>	12	38	18x14 x8,5	12.9	-	25 📦
<b>5940070</b> 	12	39	18,5 x14,5	10.9	BC1239D125	25 📦
<b>5940071</b> 	12	39	18,5 x14,5	10.9	BC1239G125	25 📦
<b>5940265</b>	12	50	16x13,5	12.9	-	25 📦
<b>3705770</b>	12	50	16x13,5	12.9	-	10 🌐
<b>234275</b>	16	50	-	12.9	-	25 📦
<b>5940330</b>	14	32	18x17	12.9	-	25 📦

Ref	Ø	A	Cx B	Classe	OEM	📦
				Standing Clase Klasa Klasse Klasse		
<b>3705808</b>	14	32	18x17	12.9	-	10 🌐
<b>KVE013332R</b> 	14	34	-	12.9	KK013332R	40 📦
<b>5940332</b>	14	34	18x17	12.9	KK013332R	25 📦
<b>3705812</b>	14	34	18x17	12.9	KK013332R	10 🌐
<b>5940270</b>	14	39	17,5x14	12.9	-	25 📦
<b>3705774</b>	14	39	17,5x14	12.9	-	5 🌐
<b>5940340</b>	14	45	-	12.9	-	25 📦
<b>257385</b>	1/2"	35	-	12.9	-	25 📦
<b>5940290</b>	1/2"	35	15,5 x17,8	12.9	-	25 📦
<b>3705784</b>	1/2"	35	15,5 x17,8	12.9	-	10 🌐
<b>5940230</b>	1/2"	39	18,6x15	12.9	-	25 📦
<b>3705742</b>	1/2"	39	18,6x15	12.9	VI1103	10 🌐
<b>5940228</b>	1/2"	39	18,6x15	12.9	VI1103	25 📦
<b>3705741</b>	1/2"	39	18,6x15	12.9	VI1103	12 🌐
<b>260532</b>	1/2"	50	18,6x15	12.9	VI1104	25 📦
<b>5940232</b>	1/2"	50	18,6x15	12.9	VI1104	25 📦



 Flat countersunk head with square neck  
 Cabeza fresada con cuello cuadrado  
 Parafusos de cabeça escareada com pescoço quadrado  
 Śruby z łbem walcowym kołnierz kwadratowy  
 Senkschrauben mit Vierkantansatz

# Boulons tête fraisée Collet carré

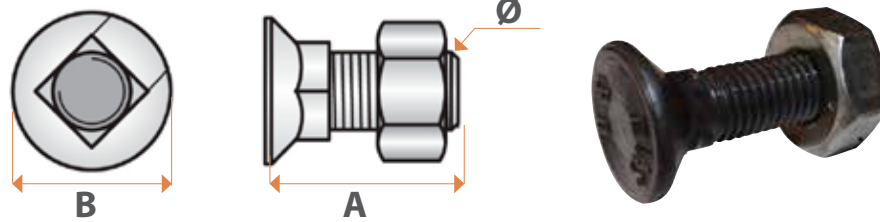

Ref	Ø	A	B	Classe	OEM	
				Standing Classe Klasa Klasse		
5940150	9	25	17	8,8	-	25
5915120	9	30	16,5	8,8	-	25
3705310	9	30	16,5	8,8	-	10
5915125	9	35	16,5	8,8	-	25
3705314	9	35	16,5	8,8	-	10
229005	9	40	16,5	8,8	-	25
5915130	10	25	18,5	8,8	-	25
5915433	10	25	18,5	12,9	-	25
5915135	10	30	18,5	8,8	-	25
3705322	10	30	18,5	8,8	-	10
5915435	10	30	18,5	12,9	-	25
5940154	10	30	19	8,8	-	25
5915140	10	35	18,5	8,8	-	25
3705326	10	35	18,5	8,8	-	10
5915440	10	35	18,5	12,9	-	25
3705449	10	35	18,5	12,9	-	10
5940155	10	37	19	8,8	-	25
3705698	10	37	19	8,8	-	10

Ref	Ø	A	B	Classe	OEM	
				Standing Classe Klasa Klasse		
5915145	10	40	18,5	8,8	-	25
3705330	10	40	18,5	8,8	-	10
5915445	10	40	18,5	12,9	-	25
3705450	10	40	18,5	12,9	-	10
5915150	10	45	18,5	8,8	-	25
5915155	10	50	18,5	8,8	-	25
3705338	10	50	18,5	8,8	-	10
5915160	10	60	18,5	8,8	-	25
3705340	10	60	18,5	8,8	-	10
234205	10	70	18,5	8,8	-	25
5915170	11	30	22	8,8	-	25
5915175	11	35	22	8,8	-	25
3705354	11	35	22	8,8	-	10
5940120	11	35	18,5	8,8	-	25
5915450	11	35	18,5	12,9	-	25
5915180	11	40	22	8,8	-	25
3705358	11	40	22	8,8	-	10
5915185	11	45	22	8,8	-	25





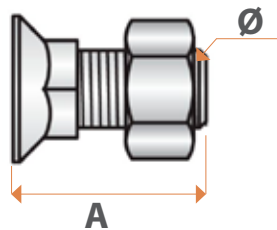

# BOULONS TÊTE FRAISÉE COLLET CARRÉ



Ref	Ø	A	B	Classe	OEM	📦	
				Standing Clase Klasa Klasse			
3705362	11	45	22	8,8	-	10	🌐
5915190	11	50	22	8,8	-	25	📦
3705366	11	50	22	8,8	-	10	🌐
5915192	11	55	22	8,8	-	25	📦
5915195	11	60	22	8,8	-	25	📦
3705370	11	60	22	8,8	-	10	🌐
5915200	11	70	22	8,8	-	25	📦
3705374	11	70	22	8,8	-	10	🌐
5915210	12	30	23,5	8,8	-	25	📦
3705382	12	30	23,5	8,8	-	10	🌐
5915510	12	30	23,5	12,9	-	25	📦
5915215	12	35	23,5	8,8	-	25	📦
3705386	12	35	23,5	8,8	-	10	🌐
5915515	12	35	23,5	12,9	-	25	📦
3705460	12	35	23,5	12,9	-	10	🌐
5940236	12	35	23,3	10,9	VI1008	25	📦
3705748	12	35	23,3	10,9	VI1008	10	🌐
5940158	12	36	21,5	8,8	-	25	📦









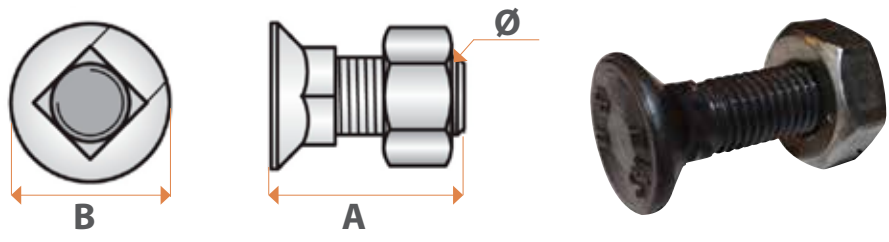







Ref	Ø	A	B	Classe	OEM	📦	
				Standing Clase Klasa Klasse			
3705704	12	36	21,5	8,8	-	10	🌐
5915220	12	40	23,5	8,8	-	25	📦
3705390	12	40	23,5	8,8	-	10	🌐
5915520	12	40	23,5	12,9	-	25	📦
3705461	12	40	23,5	12,9	-	10	🌐
5940238	12	40	23,3	10,9	VI1414	25	📦
5940238	12	40	-	8,8	VI1009	25	📦
5915225	12	45	23,5	8,8	-	25	📦
3705394	12	45	23,5	8,8	-	10	🌐
5915525	12	45	23,5	12,9	-	25	📦
5940160	12	45	21,5	8,8	-	25	📦
3705708	12	45	21,5	8,8	-	10	🌐
5915230	12	50	23,5	8,8	-	25	📦
3705398	12	50	23,5	8,8	-	10	🌐
5915530	12	50	23,5	12,9	-	25	📦
3705463	12	50	23,5	12,9	-	10	🌐
5915235	12	55	23,5	8,8	-	25	📦
3705402	12	55	23,5	8,8	-	10	🌐























 Flat countersunk head with square neck  
 Cabeza fresada con cuello cuadrado  
 Parafusos de cabeça escareada com pescoço quadrado  
 Śruby z łbem walcowym kołnierz kwadratowy  
 Senkschrauben mit Vierkantansatz

# Boulons tête fraisée COLLET CARRÉ



Ref	Ø	A	B	Classe	OEM	
				Standing Clase Klasa Klasse		
5915535	12	55	23,5	12,9	-	25 
5915240	12	60	23,5	8,8	-	25 
3705406	12	60	23,5	8,8	-	10 
5915540	12	60	23,5	12,9	-	25 
3705465	12	60	23,5	12,9	-	10 
5940162	12	60	21,5	8,8	-	10 
5915242	12	65	23,5	8,8	-	25 
5915245	12	70	23,5	8,8	-	25 
3705410	12	70	23,5	8,8	-	10 
5915545	12	70	23,5	12,9	-	25 
3705467	12	70	23,5	12,9	-	10 
5915250	12	80	23,5	8,8	-	25 
3705414	12	80	23,5	8,8	-	10 
5915550	12	80	23,5	12,9	-	25 
3705468	12	80	23,5	12,9	-	10 
5915255	12	90	23,5	8,8	-	25 
5915555	12	90	23,5	12,9	-	25 
3705470	12	90	23,5	12,9	-	10 

Ref	Ø	A	B	Classe	OEM	
				Standing Clase Klasa Klasse		
5915257	12	100	23,5	8,8	-	25 
3705418	12	100	23,5	8,8	-	10 
260248	12	110		10,9	-	50 
5915270	14	35	27,5	8,8	-	25 
3705422	14	35	27,5	8,8	-	10 
 5940240	14	35	27	10,9	VI1012	25 
 3705750	14	35	27	10,9	VI1012	10 
5940170	14	36	23,5	8,8	-	25 
3705724	14	36	23,5	8,8	-	10 
5915275	14	40	27,5	8,8	-	25 
3705426	14	40	27,5	8,8	-	10 
5915560	14	40	27,5	12,9	-	25 
5915280	14	50	27,5	8,8	-	25 
3705430	14	50	27,5	8,8	-	10 
5915565	14	50	27,5	12,9	-	25 
5915285	14	60	27,5	8,8	-	25 
3705434	14	60	27,5	8,8	-	10 
5915570	14	60	27,5	12,9	-	25 

# BOULONS TÊTE FRAISÉE COLLET CARRÉ

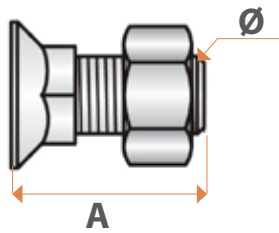

Ref	Ø	A	B	Classe	OEM	📦
				Standing Clase Klasa Klasse Klasse		
5915574	14	70	27,5	12,9	-	25 📦
5915287	14	80	27,5	8,8	-	25 📦
5915578	14	80	27,5	12,9	-	25 📦
3705484	14	80	27,5	12,9	-	10 🌐
5915288	14	90	27,5	8,8	-	25 📦
5915582	14	90	27,5	12,9	-	25 📦
5915305	16	50	32	8,8	-	10 📦

Ref	Ø	A	B	Classe	OEM	📦
				Standing Clase Klasa Klasse Klasse		
5915310	16	60	32	8,8	-	10 📦
5915315	16	70	32	8,8	-	10 📦
5915320	16	80	32	8,8	-	10 📦
5940285	3/8"	35	15	8,8	-	25 📦



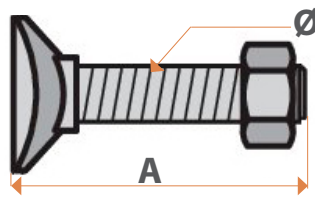

# BOULONS TÊTE FRAISÉE RECTANGLE COLLET CARRÉ



Ref	Ø	A	B	Classe	OEM	📦
				Standing Clase Klasa Klasse Klasse		
5945900	12	60	30x25	12,9	-	25 📦
3705900	12	60	30x25	12,9	-	10 🌐
5945902	12	70	30x25	12,9	-	25 📦





Ref	Ø	A	B	Classe	OEM	📦
				Standing Clase Klasa Klasse Klasse		
3705902	12	70	30x25	12,9	-	10 🌐
5945713	12	80	19x16	8,8	-	25 📦
3705896	12	80	19x16	8,8	-	10 🌐



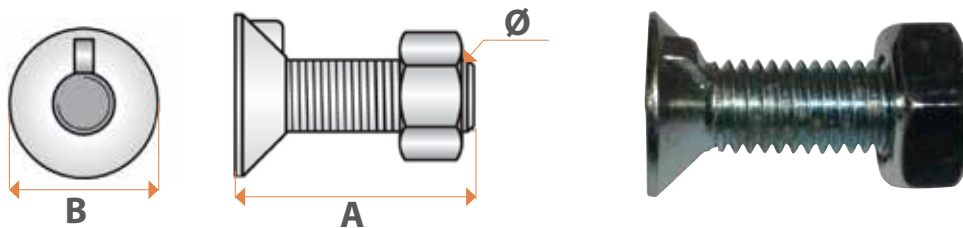

 Flat countersunk heads 1 and 2 nibs  
 Cabeza fresada 1 and 2 prisioneros  
 Parafusos de cabeça escareada com 1 e 2 olhais  
 Śruby z łbem stożkowym z 1 i 2 wypustami  
 Senkschrauben 1 and 2 nase









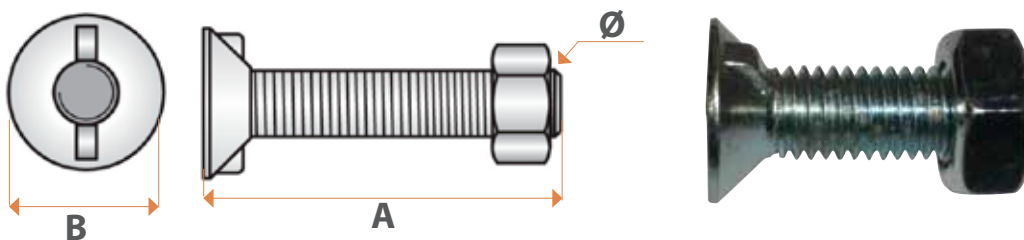

# BOULONS TÊTE FRAISÉE A 1 ET 2 ERGOTS













Ref	Ø	A	B	Classe	OEM	
				Standing Clase Klasa Klasse Klasse		
<b>NAU051805</b> <b>NAUD</b>	10	30	-	8.8	051805 04020205	25 
<b>5940374</b>	10	30	19	8.8	051805 04020205	25 
<b>3705858</b>	10	30	19	8.8	051805 04020205	10 

Ref	Ø	A	B	Classe	OEM	
				Standing Clase Klasa Klasse Klasse		
<b>5940380</b>	12	35	23	8.8	-	25 
<b>3705862</b>	12	35	23	8.8	-	10 



2 ERGOTS						
Ref	Ø	A	B	Classe	OEM	
				Standing Clase Klasa Klasse Klasse		
<b>5925130</b>	10	30	16	8,8	033006R	25 
<b>3705570</b>	10	30	16	8,8	033006R	10 
<b>5925135</b>	10	35	16	8,8	033006R	25 
<b>3705574</b>	10	35	16	8,8	003006R	10 
<b>5925140</b>	10	40	16	8,8	-	25 
<b>3705578</b>	10	40	16	8,8	-	10 
<b>KUHN 226674</b>	10	50	16	-	H0609520	25 
<b>5925150</b>	10	50	16	8,8	H0609520	25 
<b>3705586</b>	10	50	16	8,8	H0609520	10 
<b>227445</b>	10	55	16	8,8	-	25 

Ref	Ø	A	B	Classe	OEM	
				Standing Clase Klasa Klasse Klasse		
<b>5940220</b>	11	30	20	10,9	VI1202	25 
<b>3705736</b>	11	30	20	10,9	VI1202	10 
<b>5940220</b>	11	30	20	10,9	VI1202	25 
<b>240046</b>	11	35	20	10,9	VI1203	1 
<b>5940222</b>	11	40	20	10,9	VI1204	25 
<b>3705738</b>	11	40	20	10,9	VI1204	10 
<b>5940224</b>	11	50	20	10,9	VI1205	25 
<b>3705739</b>	11	50	20	10,9	VI1205	10 
<b>KUHN 226675</b>	12	30	20	-	H0609350	25 
<b>3705594</b>	12	30	20	8,8	051824 03020505	10 
<b>5925170</b>	12	30	20	8,8	051824 03020505	25 
<b>KUHN 226676</b>	12	35	20	-	H0609360 901122	25 





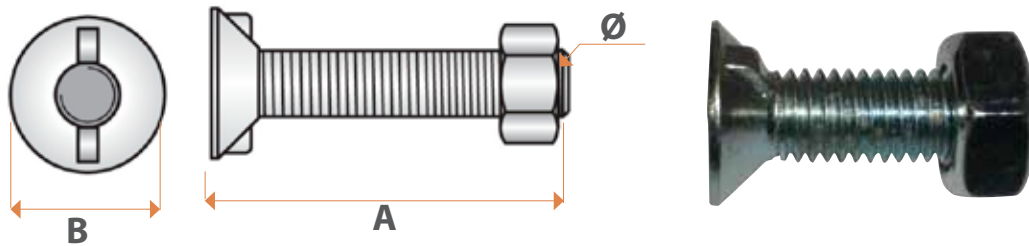

# BOULONS TÊTE FRAISÉE A 1 ET 2 ERGOTS



2 ERGOTS						
Ref	Ø	A	B	Classe Standing Clase Klasa Klasse Klasse	OEM	
269996	12	35	20	12,9	-	50
NAU051824 NAUD	12	35	20	8,8	051824 03020505	25
5925175	12	35	20	8,8	033107R	25
3705598	12	35	20	8,8	033107R	10
5925650	12	35	20	12,9	-	25
226677	12	40	20	-	H0609370	25
3705602	12	40	20	8,8	-	10
5925180	12	40	20	8,8	-	25
226678	12	45	20	-	H0609380 901124	25
5925185	12	45	20	8,8	-	25
266750	12	45	20	12,9	-	25
3705606	12	45	20	8,8	-	10
5925190	12	50	20	8,8	-	25
3705610	12	50	20	8,8	-	10
5910712	12	50	20	10,9	-	25
3705266	12	50	20	10,9	-	10
226679	12	60	20	-	H0609410	1
5925195	12	60	20	8,8	-	25
3705614	12	60	20	8,8	-	10
5910220	12	60	20	12,9	-	25
5910714	12	64	-	10,9	-	25

Ref	Ø	A	B	Classe Standing Clase Klasa Klasse Klasse	OEM	
3705268	12	64	-	10,9	-	10
5910222	12	70	-	12,9	-	25
5910224	12	80	-	12,9	-	25
NAU051842 NAUD	14	30	22,5	8,8	051842 03050205	25
5940364	14	30	22,5	8,8	051842 03050205	25
3705850	14	30	22,5	8,8	051842 03050205	10
226680	14	35	24	-	H0609430	25
5925210	14	35	24	8,8	H0609430	25
3705622	14	35	24	8,8	H0609430	10
226681	14	40	24	-	H0609440	25
3705626	14	40	24	8,8	-	10
5925215	14	40	24	8,8	-	25
NAU051849 NAUD	14	40	22,5	8,8	051849 03050405	25
5940372	14	40	22,5	8,8	051849 03050405	25
3705854	14	40	22,5	8,8	051849 03050405	10
226682	14	45	24	-	H0609450	25
228967	14	45	24	8,8	-	25
NAU051854 NAUD	14	45	-	8,8	051854 03053405	25
5925220	14	50	24	8,8	-	25
3705630	14	50	24	8,8	-	10



-  Oval heads bolts with square neck
-  Cabeza oval con cuello cuadrado
-  Parafusos de cabeça oval com pescoço quadrado
-  Śruby z łbem okrągłym kołnierz owal
-  Ovalkopfschrauben mit vierkantansatz

# BOULONS TÊTE OVALE COLLET CARRÉ

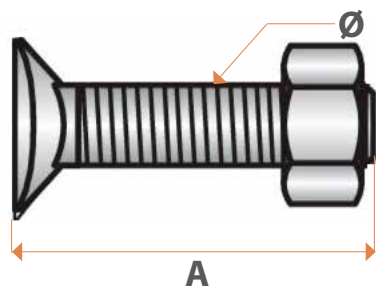

Ref	Ø	A	Classe Standing Clase Klasa Klasse Klasse	OEM	
5910108	8	33	8.8	-	50 
5910125	10	35	8.8	-	50 
3705234	10	35	8.8	-	20 
5910135	10	38	8.8	-	50 
3705246	10	38	8.8	-	20 
5910140	10	45	8.8	-	50 
5910141	10	50	8.8	-	25 
5910145	10	60	10.9	-	25 
253472	11	45	8.8	-	25 
5910155	11	60	8.8	-	25 
253471	11	80	8.8	-	25 



Ref	Ø	A	Classe Standing Clase Klasa Klasse Klasse	OEM	
5910170	12	50	8.8	-	50 
5910165	12	50	8.8	-	25 
3705260	12	50	8.8	-	10 
2910712	12	50	10.9	-	25 
3705266	12	50	10.9	-	10 
5910174	12	60	8.8	-	25 
3705264	12	60	8.8	-	10 
5910714	12	64	10.9	-	25 
3705268	12	64	10.9	-	10 
270648	12	64	8.8	-	25 



Round heads bolts with square neck  
 Cabeza redonda con cuello cuadrado  
 Parafusos de cabeça redonda com pescoço quadrado  
 Śruby z łbem okrągłym kołnierz kwadratowy  
 Rundkopfschrauben mit vierkantansatz

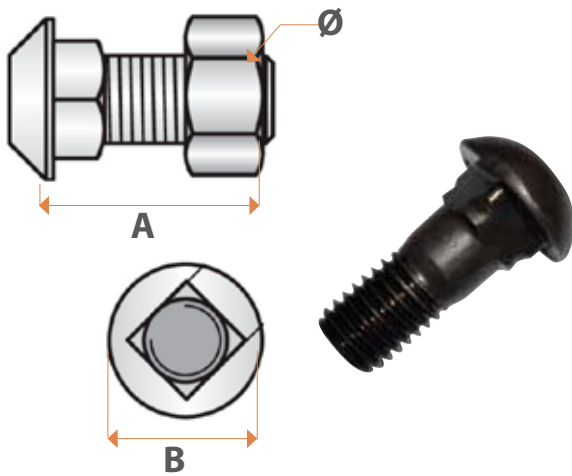





## BOULONS TÊTE RONDE COLLET CARRÉ

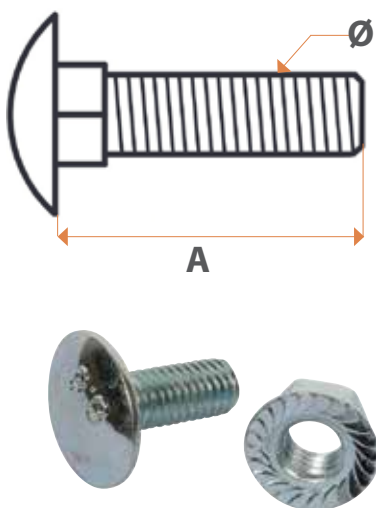





Ref	Ø	A	Classe	OEM		
			Standing Clase Klasa Klasse			
5940344	12	30	12.9	3011806	25	
5940348	12	40	12.9		25	

## BOULONS TÊTE RONDE COLLET CARRÉ BAS





Ref	Ø	A	Classe		
			Standing Clase Klasa Klasse		
1728720	8	20	8.8	200	
1728721	8	25	8.8	200	
1728722	8	30	8.8	200	
1728723	8	40	8.8	200	
1728724	10	25	8.8	100	
1728726	10	50	8.8	100	
1728727	10	60	8.8	100	
1728728	12	30	8.8	50	
1728729	12	40	8.8	50	

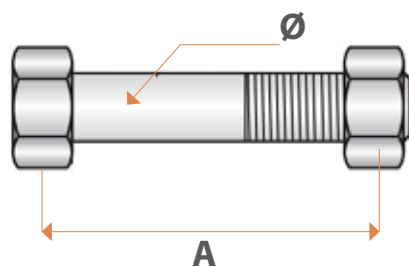

 Hex head bolts  
 Cabeza hexagonal  
 parafuso de cabeça hexagonal  
 Šruba z hlavem šestiúhelníkovým  
 Sechskantbolzen

# BOULONS TÊTE HEXAGONALE



Ref	Ø	A	Classe	OEM	
			Standing Clase Klasa Klasse Klasse		
	(mm)	(mm)			
<b>5905140</b>	1/2"	35	8.8	-	25 
<b>3705080</b>	1/2"	35	8.8	-	10 
<b>269247</b>	10x100	30	12.9	-	25 
<b>5905120</b>	11x125	35	10.9	-	25 
<b>3705060</b>	11x125	35	10.9	-	10 
<b>5905128</b>	12x125	35	12.9	-	25 
<b>5905130</b>	12x125	45	12.9	-	25 
<b>3705070</b>	12x125	45	12.9	-	10 
<b>5905160</b>	14x150	40	12.9	M00567201R M00567211R	25 
<b>3705094</b>	14x150	40	12.9	M00567201R M00567211R	10 
<b>5905170</b>	14x150	50	12.9	-	25 
<b>3705098</b>	14x150	50	12.9	-	10 
<b>5905180</b>	14x150	60	12.9	-	25 
<b>3705102</b>	14x150	60	12.9	-	10 
<b>5905150</b>	14x200	35	8.8	-	25 

Ref	Ø	A	Classe	OEM	
			Standing Clase Klasa Klasse Klasse		
	(mm)	(mm)			
<b>5905190</b>	16x150	40	12.9	-	25 
<b>3705110</b>	16x150	40	12.9	-	10 
<b>5905200</b>	16x150	45	10.9	-	25 
<b>3705114</b>	16x150	45	10.9	-	10 
<b>5905202</b>	16x150	47	12.9	-	25 
<b>3705118</b>	16x150	47	12.9	-	10 
<b>5905204</b>	16x150	50	12.9	-	25 
<b>5905208</b>	16x150	55	12.9	-	25 
<b>3705126</b>	16x150	55	12.9	-	10 
<b>5905210</b>	16x150	60	12.9	-	25 
<b>3705130</b>	16x150	60	12.9	-	10 
<b>223181</b> 	16x150	70	12.9	KK032774	1 
<b>5905541</b>	16x150	70	12.9	-	25 
<b>5905570</b> 	18x150	50	10.9	MA0002032	25 
<b>229010</b>	7/16"	32	8.8	-	25 





Nuts  
Tuercas  
Noz  
Nakrętka  
Muttern

## ÉCROUS

### BLOC DENT DOUBLE ÉCROUS

Double nut tine block

Pletina doble tuerca

Mocowanie z 2 ba

Block zahn dopperlmutter

Ref	Ø	Pas		Type	1	
		Tread width Paso Gwint Gewinde		Type Para tipo Tipo Typ Passend zu		
5972280	16	150		MASCHIO	1	
5972282				MASCHIO	1	
RAB84370071				RABEWERK	1	



### ÉCROU

Nuts

Tuercas

Nakrętka

Muttern

Ref	Ø	Pas	Type	25	
		Tread width Paso Gwint Gewinde	Type Para tipo Tipo Typ Passend zu		
5972105	22	200	AGRATOR	25	



### ÉCROU FREIN A EMBASE

Brake nut with base plate

Tuerca de freno con placa base

Nakrętka somokontrująca z kołnierzem

Sicherungsmutter mit Flansch

Ref	Ø	Pas	L	H	Classe	25	
		Tread width Paso Gwint Gewinde			Standing Clase Klasa Klasse		
5972192	14	150	27.5	18	10.9	25	
5972194	16	150	29	22	10.9	25	

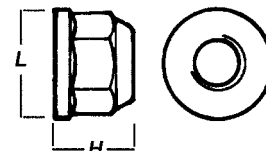

# ÉCROUS





## ÉCROU FREIN CHANFREINÉ

Brake nut Bevel

Tuerca de freno biselada

Nakrętka somokontrująca skośna

Sicherungsmutter abgeschrägt

Ref	Ø	Pas	Type		
		Tread width Paso Gwint Gewinde	Type Para tipo Tipo Typ Passend zu		
5972144	20	150	Fixation de dent de herse rotative	25	
3705926				10	









## ÉCROU FREIN NON CHANFREINÉ

Brake nut no Bevel

Tuerca de freno no biselada

Nakrętka somokontrująca

Sicherungsmutter

Ref	Ø	Pas	Type		
		Tread width Paso Gwint Gewinde	Type Para tipo Tipo Typ Passend zu		
5972136	16	150	-	25	
5972146	20	150	-	25	
3705930	20	150	-	10	
5972160	22	150	10.9	25	
5972166	24	200	-	10	



# LES PIÈCES D'USURE AU CARBURE

CARBIDE WEARING PARTS | REPUESTOS DE CARBURO DE TUNGSTENO | PEÇAS DE DESGASTE DE CARBONETO |  
CZĘŚCI ZUŻYWAJĄCE SIĘ Z WĘGLIKÓW SPIEKANYCH | HARTMETALL VERSCHLEISSTEILE |



## DURÉE DE VIE 4 À 7 FOIS SUPÉRIEURE

Lifetime from 4 to 7 times longer than normal | Duración 4 hasta 7 veces mejor | Vida útil 4 a 7 vezes mais longa |  
Od 4 do 7 razy dłuższa żywotność | Lebensdauer 4 bis 7 mal länger als normal

## RÉDUCTION DES COÛTS D'INTERVENTION

Costs of intervention reduced | Reducción de los costes de intervención | Redução dos custos de intervenção |  
Obniżone koszty interwencji | Reduzierte Einsatzkosten

## EFFICACE DANS TOUS LES TYPES DE SOLS (TRÈS USANTS OU NON)

Efficient in all kinds of soil | Eficaz en todos los tipos de suelo (muy o no usando) | Eficaz em todos os tipos de solos (com ou sem des-  
gaste acentuado) | Skuteczny na wszystkich rodzajach podłoży (z dużym zużyciem lub nie) | Wirksam in allen Bodenarten

## MAINTIEN DE LA GÉOMÉTRIE DE LA PIÈCE

Maintaining the geometry of the part | Mantenimiento de la geometría de la pieza | Mantem a geometria da peça | Utrzymanie  
geometrii części | Beibehaltung der Geometrie des Teils

## AMÉLIORATION DE LA QUALITÉ DU TRAVAIL

Improved quality of work | Mejora de la calidad del trabajo | Melhora a qualidade do trabalho | Poprawa jakości pracy |  
Verbesserte Arbeitsqualität

## INVESTISSEMENT RENTABLE

Profitable Investment | Inversión rentable | opłacalna inwestycja | Investimento lucrativo | Effiziente Investition

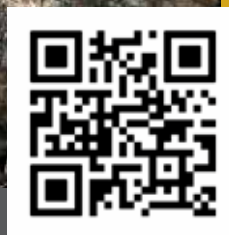

Route de Saint Malo ZA de Beaucé  
FR- 35 520 LA MEZIERE



[contact@fournial.fr](mailto:contact@fournial.fr)



+ 33 (0)2 99 13 05 00

*Scan me!*

